



SUBSCRIPTION MAIL

Rate Card

Royal Mail Subscription Mail®

02 January 2025



Helping your business thrive and prosper

Royal Mail is the UK's designated Universal Postal Service Provider, supporting customers, businesses and communities across the country. We are the only company that has the capability to deliver a 'one price goes anywhere', six days a week service on a range of letters and parcels to more than 31 million addresses across the UK.

Online Price Calculator

Use our online price calculator to find the best options for your mailing. There's also a downloadable Excel version. royalmailtechnical.com/calculator

For prices that are changing in January 2025 please visit: royalmail.com/prices2025 For all other prices visit royalmail.com/current-postage-prices

Although correct at the time this rate card was produced (December 2023), postal prices, fees and other conditions are subject to revision from time to time and services may need to be added or withdrawn.

Up-to-date information may be obtained by visiting royalmail.com

Subscription Mail

Subscription Mail is our subscription magazine service, where items posted contain 30% or more editorial content.

We consulted the sector and customers told us they need certainty to grow their subscriptions. Subscription Mail offers up to 12 months' price certainty so that customers can plan ahead and invest in launching new titles.

Know your formats

The available format for Subscription Mail is Large Letter. The illustration below shows the maximum dimensions and maximum weight permitted.

Mailmarked Large Letter – machine readable Up to 750g

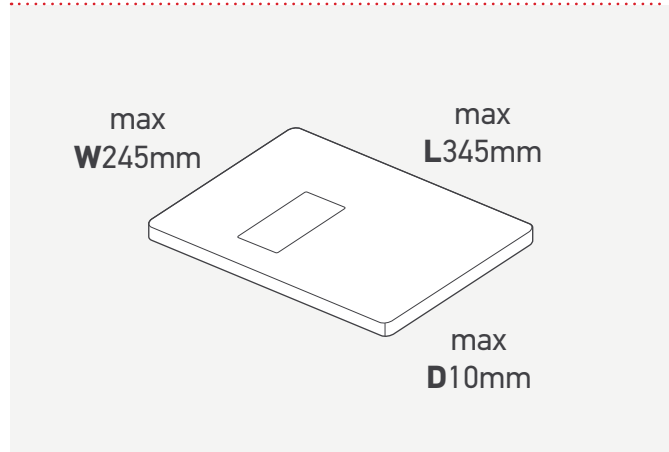

Manual Large Letter

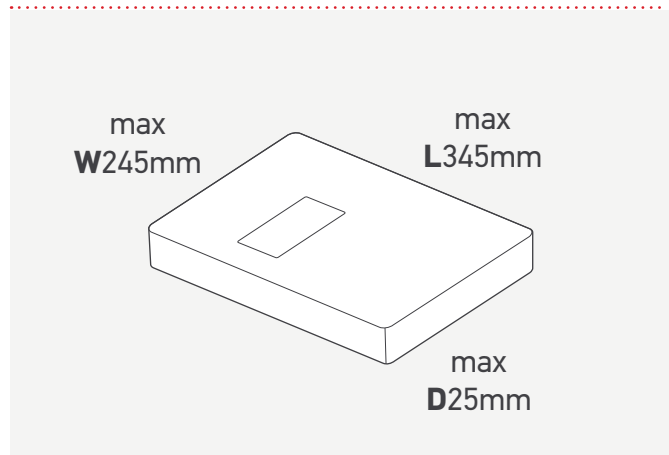

Subscription Mail

Large Letters

Low Sort and Manual Options

Delivery Speed	Sort Option	Product Code	Weight up to and including	Price Type	Number of Direct items per day*				
					1,000-9,999	10,000-19,999	20,000-39,999	40,000-59,999	60,000+
1st Class	Large Letter Mailmark	PQC	100g	Full price	70.4p	69.6p	68.4p	67.4p	66.9p
			250g	Full price	77.6p	76.7p	75.4p	74.3p	73.7p
			750g	Base price	77.6p	76.7p	75.4p	74.3p	73.7p
			750g	Per gram increment	0.1680p	0.1662p	0.1633p	0.1608p	0.1596p
	Large Letter Manual (up to 25mm)	SBA	100g	Full price	81.1p	80.2p	78.8p	77.6p	77.0p
			250g	Full price	89.6p	88.6p	87.1p	85.7p	85.1p
			750g	Base price	89.8p	88.8p	87.3p	85.9p	85.3p
			750g	Per gram increment	0.1922p	0.1901p	0.1868p	0.1839p	0.1826p
2nd Class	Large Letter Mailmark	PQD	100g	Full price	50.7p	50.1p	49.3p	48.5p	48.2p
			250g	Full price	65.2p	64.5p	63.4p	62.4p	61.9p
			750g	Base price	67.1p	66.4p	65.2p	64.2p	63.7p
			750g	Per gram increment	0.1496p	0.1480p	0.1454p	0.1432p	0.1421p
	Large Letter Manual (up to 25mm)	SBB	100g	Full price	61.4p	60.7p	59.7p	58.8p	58.3p
			250g	Full price	78.9p	78.0p	76.7p	75.5p	75.0p
			750g	Base price	79.3p	78.4p	77.1p	75.9p	75.3p
			750g	Per gram increment	0.1721p	0.1702p	0.1673p	0.1647p	0.1635p

Prices in this table exclude VAT, which is charged at the standard rate.

Mailings of fewer than 1,000 items may be charged at a higher rate.

*Volume Related Discounts for direct items are based on total daily volumes over multiple sales order lines providing all items are posted on the same day, posted from the same posting location (site), and posted via the same product, format and magazine code, and only applies to direct items (residue items are not counted towards the calculation).

Large Letters

Low Sort Trayed Mail Savings

Saving per item	
Low Sort Trayed Mail Savings	
Large Letters*	2.00p

*Maximum depth of 25mm applies to Subscription Mail Large Letters.

Prices in this table exclude VAT, which is charged at the standard rate.

Tray Savings apply after all other discounts (VRDs, sortation, profile price, etc) are applied but before VAT.

Trayed Mail discounts subject to change and will be applied at the prevailing rate.

Calculating the Price of Your Mailing

Prices in this guide for Large Letters include the sortation, machine-readable and Volume Related Discounts (VRD), where applicable, and do not need to be calculated separately.

This means the calculation has been simplified for Large Letter sorted options from 251 grams up to 750 grams.

Calculating the price of your mailing

Step 1:

All prices are shown for Large Letters up to 250g so no additional calculations are required.

If the item is Large Letter format and weighs more than 250g, then an incremental price should be added to the base price based on the exact weight of the item.

Find the base price and per-gram increment price from the Large Letters table on the previous page.

The incremental price is calculated as the incremental weight in grams above 250g multiplied by the gram price increment. The result is rounded to the nearest 1/10th of a penny.

High Sort options are not available with Subscription Mail so additional calculations are not required for direct and residual values.

Step 2

Apply any Trayed Mail savings.

Apply VAT as appropriate (MASBOF/JICMAIL levies only apply to Advertising Mail).

Worked example

A Subscription Mail Mailmark 2nd Class option posting of 102,000 Large Letters weighing 302g each.

Step 1

The base price for Subscription Mail
 $= 61.9p + (302-250g) \times 0.1421p = 69.2892p$
rounded to the nearest 1/10th of a penny = 69.3p

Price of mailing = $(69.3p \times 102,000)/100$
= £70,686.00

Step 2

Low Sort Large Letter mailings presented in trays will save 2.00p per item = $(2.00p \times 102,000)/100$
= £2,040.00

Total tray price of mailing = £70,686.00 - £2,040.00
= £68,646.00 (excluding VAT).

Contact

We hope that this tariff guide has been useful, but should you need any further help or advice, please contact your Account Manager, call the customer helpline: **03457 950 950** or contact us through our website: **royalmail.com/contact**

Alternative formats

If it would help you to have this booklet in a different format, we can provide it free of charge as:

A large-print booklet An audio tape
An audio CD A Braille booklet

Simply call us on **03457 950 950**.

If you're deaf or hearing or speech-impaired, we offer a service using the Relay UK service. Please dial Royal Mail **18001 0345 266 0075**.

We're open Monday to Friday 8am-6.30pm, Saturday 8am-3pm and Sunday 9am-2pm.

Alternatively, using your minicom, please dial **03456 000 606**. The service is open Monday to Friday 8am-6pm and Saturday 8am-1pm.

Royal Mail and the cruciform are trade marks of Royal Mail Group Limited.
© Royal Mail Group Limited 2024. All rights reserved. Royal Mail Group Limited, registered in England and Wales, number 4138203, registered office: 185 Farringdon Road, London, EC1A 1AA.