

# **PUBLISHING MAIL®**

## **SUMMARY OF INFORMATION**

### **TABLE OF CONTENTS**

Definition of eligibility

Entry requirements

Formats

Delivery speeds

Payment options

Payment indicia

Sorted options

Qualification and set up

Availability of Publishing Mail with other Royal Mail offers

Pricing options

### **DEFINITION OF ELIGIBILITY FOR PUBLISHINGMAIL**

Publishing Mail is our service for sending periodical items such as newsletters, journals and magazines (but not brochures, catalogues, directories and exhibition guides). Before customers can use the service, we need to verify that items meet our qualifying criteria: -

1. At least one-sixth of the periodical must be editorial content
  - Editorial content does not include advertising material or data or any information relating to a product or service such as pricing information or product descriptions, which relate to either the publisher of the magazine, the owner of the magazine or a third party the front and back covers are not included in calculating editorial content.
2. The front cover of each publication must clearly show its title and at least one of the following:
  - the date of issue
  - the month
  - the season
  - issue number
3. It must be published and posted using the Publishing Mail service at least twice a year

## ENTRY REQUIREMENTS

- Publishing Mail is available as a sorted product only.
- Each posting must contain at least 1,000 Large Letters. In certain circumstances, it is possible to send out smaller amounts but please note that any postings of less than 1,000 items will be charged as 1,000 standard Publishing Mail items and no discount shall be applicable. For more information, please talk to your account manager.
- We require a sample of each item required for verification of its eligibility

## PUBLISHING MAIL OPTIONS

There are a range of options for you to choose from, enabling you to select what is most appropriate for your needs.

- Low Sort, address printed with mail pieces printed with Royal Mail Mailmark® barcodes, available for large letters only.
- Manual Low Sort

## FORMATS

### Large Letter

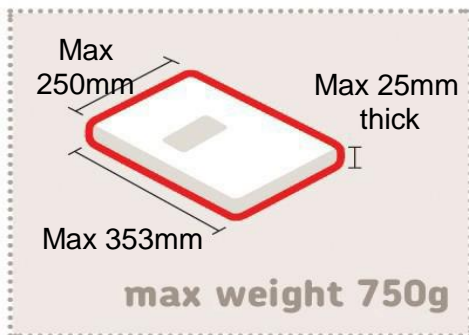

### Large letter - machine readable



Large Letters (Manual non-machine readable and)

- Max size 250mm x 353mm (excluding packaging).
- Max thickness 25mm
- Max weight 750g

Large Letters (machine readable and Low Sort)

- Max size 245mm x 345mm (including packaging)
- Max thickness 10mm
- Max weight 750g

For the purposes of non-machine readable items only, the size definitions for length (x) and width (y) for Large Letters will exclude plastic outer covers, provided these are flimsy and easily folded. i.e. the outer covers will not count towards the total dimensions of the mail piece for pricing purposes.

The outer dimensions are included for machine readable Low Sort postings.

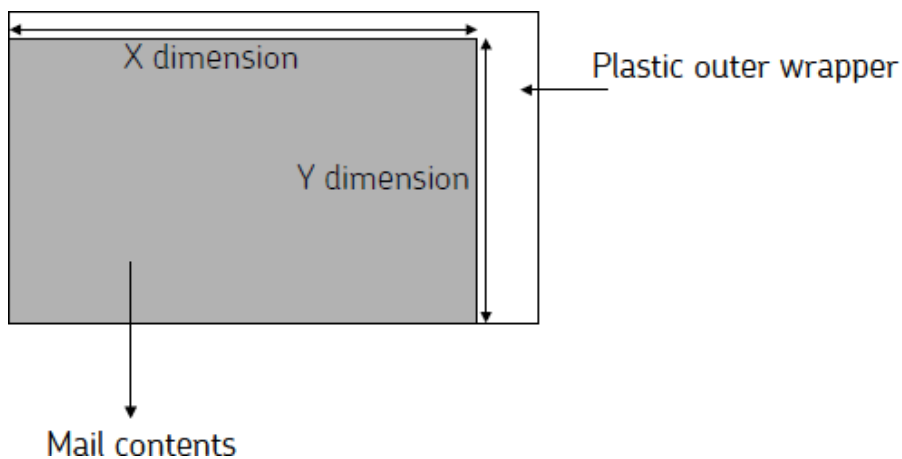

## DELIVERY SPEEDS

- 1<sup>st</sup> Class: delivery aim next working day\*
- 2<sup>nd</sup> Class: delivery aim within three working days after the day of posting

Working days are Monday – Saturday

## PAYMENT OPTIONS

Online Business Account (OBA) only

## PAYMENT INDICIA

Postage Paid Indicia (PPI's): see examples below:



There are four sizes available in the English PPI design and 3 sizes available in the bilingual Welsh/English version. Due to space restrictions the smallest bilingual PPI design is text only.

## SORTED OPTIONS

Low Sort Mailmark : for mail that meets our machine-readable specification, sort your Large Letter machine- readable format mail to our Low Sort selections and ensure your addresses can be read and mail pieces routed by our sorting machines to achieve maximum savings.

- Minimum of 1,000 Large Letters in a single mailing
- Sort to the Low Sort selections as detailed in the Royal Mail Selection Files

Use an option below:

- Royal Mail Mailmark<sup>®</sup> barcode: Mail pieces printed with a 2D<sup>1</sup> Mailmark barcode (that encodes unique information about the mail piece, information about the service being used and the participants in the supply chain) and a machine-readable font (100% address, postcode and DPS accuracy highly recommended<sup>2</sup>). Available for Letter and Large Letter formats.

<sup>1</sup> A 4-state Mailmark barcode option is also available for customers that cannot produce 2D Mailmark barcodes

<sup>2</sup> It is recommended that the address and postcode on the item is consistent with the postcode and DPS in the Mailmark barcode on the mail piece and in the eManifest. If the address, postcode & DPS accuracy drops below 90% when compared to PAF<sup>®</sup> you may see an invoice adjustment to cover the additional cost of conveying poorly addressed mail pieces. Please note: for 4-state Mailmark barcode postings a full and accurate postcode and DPS is required on each item.

\* Exclusions: Postcodes: PH19 – 50, ZE1, ZE2 & ZE3, HS1-5, HS6, HS7-8 & HS9, KW16, KW15, KW17, JE1 – JE4 and IM1 - IM9, IM86, IM87 & IM99.

#### Containers:

- Trays or bags for large letters up to 10mm in thickness
- Bags or ALPs (auto-leveling packet sleeve) for large letters over 10mm in thickness
- When using trays, you must have an average of at least 25 large letters per selection across the mailing
- Low Sort Manual:
  - Sort as detailed in Royal Mail Selection files.
  - Containers:
    - Trays, bags or segregated bundles for Letters
    - Trays, bags or segregated bundles for Large Letters up to 10mm in thickness
    - Segregated bundles or ALPs (auto-levelling packet sleeved York) for Large Letters >10mm in thickness

#### Containers:

- Trays, bags or segregated bundles for large letters up to 10mm in thickness
- Bags, segregated bundles or ALPs (auto-levelling packet sleeve) for large letters above 10mm in thickness
- For trays, you must also have an average of at least 25 large letters per selection across the mailing.

## QUALIFICATION AND SET UP FOR PUBLISHING MAIL

Before you can use Publishing Mail, we need to verify that the periodical qualifies as a newsletter, journal or magazine. The periodical needs to be assessed and can be done via the webform: <https://www.royalmail.com/business/mail/publishing-mail/apply>

#### Qualification Requirements;

The front cover of each publication must clearly show its title and at least one of the following: the date of issue, the month, the season or issue number. It must be published and posted (using the Royal Mail Publishing Mail service) at least twice a year. Each posting must contain at least 1,000 Large Letters. In certain circumstances, it's possible to send out smaller amounts.

Please note: that any Publishing Mail mailings of less than 1,000 items will be charged as 1,000 standard Publishing Mail items and no discount shall be applicable. A mail piece can contain more than one item but is subject to certain conditions.

At least 90% of the addresses on your publications must be fully and accurately addressed and postcoded in line with the Royal Mail Postcode Address File (PAF®) for the same is recommended for Mailmark barcode mailings.

At least one-six of the Periodical must be editorial content.

a) editorial content does not include advertising material or data or any information relating to a product or service such as pricing information or product descriptions, which relate to either the publisher of the magazine, the owner of the magazine or a third party

b) the front and back covers are not included in calculating editorial content

Catalogues, brochures, directories and exhibition guides are not deemed to be magazines, newsletters or journals and are therefore may not be posted as a Publishing Mail posting on their own.

Goods and articles that are in fulfilment of an order or request made to the sender, seller or supplier are prohibited.

If the periodical qualifies, a code will be issued by Royal Mail for use against that title.

For full details please see the Specific Terms and Conditions for Marketing, Publishing and General Correspondence at [www.royalmail.com/terms-and-conditions](http://www.royalmail.com/terms-and-conditions) .

## AVAILABILITY OF PUBLISHING MAIL WITH OTHER ROYALMAIL OFFERS

	1 <sup>st</sup>	2 <sup>nd</sup>
<b>Volume Related Discounts</b>	Available	Available
<b>Mailmark</b>	Available	Available

## PUBLISHING MAIL PRICING OPTIONS

Volume Related Discount (VRD)