



# User Guide for

# Mailmark Mailing Requirements for Letters and Large Letters

April 2026

*This a legally binding document forming part of the Agreement between you and Royal Mail*

**Contents**

- 1. Introduction ..... 5
  - 1.1 Applicable Products .....5
  - 1.2 Document Structure .....6
  - 1.3 Specification Requirements .....6
  - 1.4 Quality Assurance Process .....6
- 2. Mailmark Letters – Specification Requirements ..... 7
  - 2.1 Mailmark Letters – Physical .....7
    - 2.1.1 Mailmark Letters – Labels .....10
  - 2.2 Mailmark Letters – Indicia .....10
  - 2.4 Mailmark Letters – Addressing .....11
  - 2.5 Mailmark Letters – Mailmark Code .....15
  - 2.6 Mailmark Letters – Codemark Clear Zones .....17
  - 2.7 Mailmark Letters – Other Physical Requirements .....18
    - 2.7.1 Mailmark Letters – One Piece & Paper Wrap Mailers .....18
    - 2.7.2 Mailmark Letters – Perforated Mail – Requirements .....24
    - 2.7.3 Mailmark Letters – Tabbed Mailers .....31
  - 2.8 Mailmark Letters – Figures .....34
    - 2.8.1 Mailmark Letters – Physical Figures .....34
    - 2.8.2 Mailmark Letters – Addressing Figures .....36
    - 2.8.3 Mailmark Letters – Mailmark Figures .....39
    - 2.8.4 Mailmark Letters – Other Mailmark Mailer Figures .....40
- 3. Mailmark Large Letters ..... 53
  - 3.1.1 Mailmark Large Letters – Physical – Generic .....53
  - 3.1.2 Mailmark Large Letters – Physical – Paper Envelopes .....54
  - 3.1.3 Mailmark Large Letters – Physical – Paper Wrap .....55
  - 3.1.4 Mailmark Large Letters – Physical – Polymer Wrap .....57
  - 3.1.5 Mailmark Large Letters – Physical – Polymer Envelope .....57
  - 3.1.6 Mailmark Large Letters – Physical – Unwrapped (Open) Mail .....58
  - 3.2 Mailmark Large Letters – Indicia .....58
  - 3.3 Mailmark Large Letters – Addressing .....59
  - 3.4 Mailmark Large Letters – Mailmark Code .....60
  - 3.5 Mailmark Large Letters – Figures .....61

**Figures**

Figure 1 – Letter Inserts (Not to Scale)..... 34

Figure 2 – Letter Flexibility (Not to Scale) ..... 34

Figure 3 – Reference Edge (Not to Scale)..... 34

Figure 4 – Letter Sealing – Trayed (Not to Scale) ..... 35

Figure 5 – Letter Sealing – Untrayed (Not to Scale)..... 35

Figure 6 – Back Circular Window (Not to Scale)..... 35

Figure 7 – Letter Font Ratio..... 36

Figure 8 – Delivery Address Block (Not to Scale) ..... 36

Figure 9 – Letter Clear Zones – Minimum Size (Not to Scale)..... 36

Figure 10 – Letter Clear Zones – DL Envelope (Not to Scale)..... 37

Figure 11 – Letter Clear Zones – Maximum Landscape (Not to Scale)..... 37

Figure 12 – Letter Clear Zones – Maximum Portrait (Not to Scale) ..... 38

Figure 13 – Letter Return Address Preferred – Back (Not to Scale)..... 38

Figure 14 – Letter Return Address – Front Landscape Example A (Not to Scale)..... 38

Figure 15 – Letter Return Address – Front Landscape Example B (Not to Scale)..... 39

Figure 16 – 4-State Mailmark Barcode Symmetry ..... 39

Figure 17 – 4-State Mailmark Barcode Bar Skew Y (Not to Scale)..... 39

Figure 18 – 4-State Mailmark Barcode Code Skew Z (Not to Scale)..... 39

Figure 19 – Standard One-Piece Letter Mailer – Spot Weld Requirements (Not to Scale)..... 40

Figure 20 – Standard One-Piece Letter Mailer – Adhesive Line Requirements (Not to Scale) ..... 40

Figure 21 – Feature Letter Mailer (Not to Scale) ..... 40

Figure 22 – Coupon One-Piece Letter Mailer – Dimensions (Not to Scale)..... 41

Figure 23 – Coupon One-Piece Letter Mailer – Finished Back View (Not to Scale)..... 42

Figure 24 – Machineable Postcard – Option 1 (Not to Scale)..... 42

Figure 25 – Machineable Postcard – Option 2 (Not to Scale)..... 43

Figure 26 – Tamper Evident – Roulette Perforated Mailer – Landscape (Not to Scale)..... 44

Figure 27 – Tamper Evident – Roulette Perforated Mailer – Portrait (Not to Scale)..... 44

Figure 28 – Roulette Perforation Dimensions (Not to Scale) ..... 44

Figure 29 – Tamper Evident – Pressure Seal Perforated Mailer – Front Perforations (Not to Scale) ..... 45

Figure 30 – Tamper Evident – Pressure Seal Perforated Mailer – Back Perforations (Not to Scale)..... 45

Figure 31 – Fold & Seal Mailer – Open Perforations..... 45

Figure 32 – Fold & Seal Mailer – Finished Dimensions (Not to Scale) ..... 46

Figure 33 – Fold & Seal Mailer – Open Dimensions (Not to Scale) ..... 46

Figure 34 – Fold & Seal Mailer Design Options..... 47

Figure 35 – Fold & Seal Mailer with Coupon – Finished Dimensions (Not to Scale)..... 48

Figure 36 – Fold & Seal Mailer with Coupon – Open Dimensions (Not to Scale)..... 48

Figure 37 – Fold & Seal Mailer with Coupon Design Options ..... 49

Figure 38 – Zip Tie Orientation (back view) – Landscape Mail ..... 49

Figure 39 – Zip Tie Orientation (back view) – Portrait Mail..... 49

Figure 40 – Zip Tie ‘Envelope’ Flap (Not to Scale)..... 50

Figure 41 – Zip tie Dimensions (Not to Scale) ..... 50

Figure 42 – Tabbed – DL Thin Letter (Not to Scale). ..... 51

Figure 43 – Tabbed – DL Thicker / Heavier Letter (Not to Scale)..... 51

Figure 44 – Tabbed – Maximum Size Landscape Letter (Not to Scale). ..... 52

Figure 45 – Tabbed – Maximum Size Portrait (Not to Scale) ..... 52

Figure 46 – Large Letter Lateral Movement (Not to Scale)..... 61

Figure 47 – Large Letter Flexibility (Not to Scale) ..... 61

Figure 48 – Large Letter Sealing – Paper (Not to Scale) ..... 61

Figure 49 – Large Letter Sealing – Poly Envelope (Not to Scale) ..... 62

Figure 50 – Large Letter Separation – (Not to Scale)..... 62

Figure 51 – Large Letter Gatefold – (Not to Scale)..... 62

Figure 52 – Large Letter Paper Wrap – Printing (Not to scale)..... 63

Figure 53 – Large Letter Longitudinal Seal – Poly Wrap (Not to Scale) ..... 63

Figure 54 – Large Letter Return Address Preferred – Back (Not to Scale) ..... 63

Figure 55 – Large Letter Return Address – Front Landscape Example A (Not to Scale) ..... 64

Figure 56 – Large Letter Return Address – Front Landscape Example B (Not to Scale) ..... 64

Figure 57 – Large Letter Clear Zones – Landscape (Not to Scale) ..... 64

Figure 58 – Large Letter Clear Zones – Portrait (Not to Scale) ..... 65

## 1. Introduction

You can reduce the cost of your letter and large letter format mailings by making them machine- readable.

This user guide sets out the design and technical requirements and recommendations to enable you to meet the Mailmark barcode specifications for letter formats and large letter formats. The Mailmark barcode option has been designed for machine-readable items. It is not to be used with items that require manual handling.

For technical requirements that apply to OCR mailings, or full product and presentation requirements please refer to the specific product sections of the user guide for your chosen product. These can be found at [www.royalmailtechnical.com](http://www.royalmailtechnical.com)

Please note that some of the Mailmark barcode elements and specifications within this document are recommendations and not requirements.

The Mailmark option allows the performance of your mailing to be monitored and measured by the addition of a Mailmark barcode to your items. This enables Batch level reporting with item level exceptions and so gives you greater transparency of mailings. Whilst using the Mailmark option does permit some flexibility, complying with our recommendations will ensure that the performance of your mailing is maximised.

### 1.1 Applicable Products

The following products can be sent as Mailmark Barcode machine readable Letters

Category	Product Name	Options
Marketing Products	Advertising Mail	Non Sorted Low Sort
General Correspondence	Business Mail	Non Sorted Low Sort

The following products can be sent as Mailmark Barcode machine readable Large Letters.

Category	Product Name	Options
Marketing Products	Advertising Mail	Non Sorted Low Sort
Publishing Products	Publishing Mail	Low Sort
	Subscription Mail	Low Sort
General Correspondence	Business Mail	Non Sorted Low Sort

#### Please note

For Low Sort item choices, you can send your machine-readable large letters using the segregated bundles option. Please refer to the Containerisation User Guide for full details.

## 1.2 Document Structure

The document is divided into the following sections for Letter & Large Letter :-

- Physical requirements
- Indicia requirements
- Addressing requirements
- Mailmark requirements
- Codemark Clear Zones (Letters only)
- Other physical requirements

## 1.3 Specification Requirements

The document sets out physical design, Indicia, addressing, barcoding, and other Royal Mail Mailmark specifications that are required when posting Letters & Large Letters using Mailmark. Note that specific design requirements are provided for machineable Polling Cards and Do Not Redirect items.

The specifications within this document are designed to ensure that Royal Mail Letter processing machines can process and read Letters & Large Letters effectively at high speed, without the need for manual or other intervention. All the specifications as set out in this document are required.

To help you with identifying how Royal Mail treats items which do not meet the specification, we have categorised and noted individual requirements as Mandatory (M), High Risk (H) or Low Risk (L) :

- Letters & Large Letters that fail to meet the 'Mandatory' requirements are regarded as unmachineable and are very likely to have Adjustments applied.
- Letters & Large Letters which fail to meet the requirements that are identified as 'High Risk' have a higher likelihood of performing poorly through our letter processing machines. Letters & Large Letters that fail to meet these requirements are more likely to have Adjustments applied and may become damaged in our processing machines.
- Letters & Large Letters which fail to meet the requirements that are identified as 'Low Risk' may perform poorly through our letter processing machines. However, the risk is lower than that posed by failure to meet the 'High Risk' specifications and there is less chance, but still a possibility, of Letters & Large Letters being damaged or Adjustments being applied.

We have provided guidance footnotes that explain some of the risks associated with not meeting the 'Recommended' requirements. At the end of the document we have also provided all of the Figures which are referenced throughout the document, and which provide illustrative examples of the specification requirements.

**The requirements apply to the finished Letters and Large Letters as presented to Royal Mail.**

## 1.4 Quality Assurance Process

When using the Mailmark option we are able to assess the performance of your mailing. There is therefore no need for an upfront accreditation check of your mailpiece design or address, postcode and Delivery Point Suffix (DPS) accuracy.

You need to be able to create and apply Mailmark barcodes to your items and you must be able to create and upload eManifests to the eManifest Handling System. If you would like to check that you can do so successfully please contact us for support at [mailmark@royalmail.com](mailto:mailmark@royalmail.com)

For our Advertising Mail you will need to supply us with evidence that you have adhered to certain data, use of sustainable resources and recyclability requirements amongst other aspects.

Please see the specific product user guides for more detail.

## 2. Mailmark Letters – Specification Requirements

### 2.1 Mailmark Letters – Physical

Category		Specification Requirement	M/R
Size & Shape	Shape	Rectangular or square with straight sides and 90° corners	M
	Orientation	Landscape or portrait	M
	Size (H x L)	<u>Rectangular</u> Minimum – 90mm x 140mm, Maximum – 165mm x 240mm <u>Square</u> Minimum – 140mm x 140mm, Maximum – 165mm x 165mm	M
	Thickness	Minimum – 0.25mm, Maximum – 5mm	M
	Weight	Maximum – 100g	M
	Content / Inserts	<ul style="list-style-type: none"> <li>One or two standard size staples (maximum 24mm x 6mm) or paper clips (maximum 23mm long) may be inserted in the Letter.</li> <li>Other metal objects such as keys, pens, coins etc. must not be placed in the Letter.</li> <li>Inserts other than paper that are placed in an envelope should be fixed in position and attached to the largest paper insert. e.g. bank cards.</li> <li>The spines on booklet inserts should be located on the reference edge.</li> </ul>	M
			M H <sup>1</sup> H <sup>2</sup>
Lateral Movement	There are limitations on the lateral movement space that the insert may have. They are dependent upon the thickness of the Letter, and apply to the largest paper insert (see Figure 1) :- <ul style="list-style-type: none"> <li>Where the thickness is 2mm – 5mm the lateral movement should be no more than 20mm.</li> <li>Where the thickness is 0.25mm – 2mm, the lateral movement should be no more than 30mm.</li> </ul>	H <sup>3</sup>	
		L <sup>3</sup>	
Shape Cont.	Lateral Movement Cont.		
	Flexibility	<ul style="list-style-type: none"> <li>Each Letter must be capable of being transported around a pulley with a radius of 140mm with a max force of 26 N (See Figure 2) <sup>4 5</sup>.</li> <li>Perfect Bound mailers and content are not acceptable.</li> </ul>	M M
Envelope Construction & Design	Material	<ul style="list-style-type: none"> <li>Mailpieces must be made from paper only and have NO open apertures <sup>6</sup>.</li> </ul>	M
	Flaps	<ul style="list-style-type: none"> <li>The preferred location for the flap is on the long top edge and on the back of the Letter</li> <li>If the flap is on a short side of the Letter, it should be on the back left edge as viewed from the front of the Letter.</li> <li>Where the flap folds to the front (address side) of the Letter, its edge should not fall within the Codemark clear zones.</li> </ul>	H <sup>7</sup> L <sup>7</sup> L <sup>8</sup>
		Reference Edge <sup>9</sup>	The reference edge must be a fold. (This is the edge beneath the Delivery Address for landscape rectangular and square Letters, and the long edge to the left of the Delivery Address for portrait Letters.) (See Figure 3)

<sup>1</sup> Lowers the risk of moving inserts breaking through the Letter edges.

<sup>2</sup> This reduces the potential for mail damage following jams.

<sup>3</sup> Where the Letter thickness is variable and lateral movement is high, there is an increased risk of the Letter content being separated from the envelope or wrap.

<sup>4</sup> Letters must be flexible enough to wrap around a cylinder of 280mm diameter without being damaged.

<sup>5</sup> From a non-technical perspective, items should be flexible enough to bend into an 'S' shape along the longest edge.

<sup>6</sup> If you wish to apply a Mailmark barcode to Letter format Mailing Items that are poly-wrapped, unwrapped (naked) or not sealed you can do so provided that you present, declare, and pay for the items as Large Letters.

<sup>7</sup> This ensures that the Letter is strong enough to withstand the rigours of mechanical and manual handling.

<sup>8</sup> Tag codemark reading supports Mailmark reporting.

<sup>9</sup> The reference edge is a fold on a particular edge of the Letter, which enables it to be processed through the machines efficiently.

Category	Specification Requirement	M/R
Envelope Construction & Design Cont.	<b>Sealing</b> <ul style="list-style-type: none"> <li>Adhesives used must be dry and must not leak onto the outside of the Letter or produce protruding mounds on the Letter.</li> <li>Letters must not be stuck or caught together.</li> <li>Letters must be securely sealed on the front, back, and all edges.</li> <li>The adhesive must be fully cured prior to presentation of the mailing to Royal Mail.</li> <li>Letters must be flat and must not be curled.</li> <li>The adhesive must not be brittle or easily broken.</li> <li>The sealing adhesive(s) must be no more than 80 microns thick.</li> <li>Letters presented in trays should be sealed to within a minimum of 35mm from the fold of the envelope flap, and 35mm from the envelope sides (see Figure 4)</li> <li>For all other Letters, the flap should be sealed to within a minimum of 35mm from the fold of the envelope flap, and 25mm from the envelope sides (see Figure 5).</li> </ul>	M
		M
		M
		M
		M
		M
		M
		L <sup>10</sup>
		L <sup>10</sup>
		<b>Paper Weight</b> <ul style="list-style-type: none"> <li>Minimum - 70gsm for envelopes</li> <li>Recommended minimum 250gsm for postcards</li> </ul>
H <sup>7</sup>		
<b>Opacity</b>	The paper used should be at least 85 % opaque (BS ISO 2471 - Paper and board. Determination of opacity)	H <sup>11</sup>
<b>Absorbency</b>	The paper used should have an absorbency of 15-35 gsm of water in 1 minute (BS EN 20535 - Paper and board. Determination of water absorptiveness.)	H <sup>12</sup>
<b>Porosity</b>	The paper used should have a porosity value of less than 700 ml per minute (BS 6538-2 - Air permeance of paper and board.)	L <sup>13</sup>
<b>Finish - Digitally Printed Mail</b>	<p>When digital printing is used for mail, the pigment may rub off, transfer to adjacent surfaces (inserts and the envelope), crack, and become marked both during the manual and automated handling processes. The application of an ultraviolet (UV) cured varnish has been found to reduce the wear to digitally printed mail items. This provides a protective coating over the pigment. It should only be applied to the non-address side of the Letter as the characteristics of the varnish may make the mail unmachineable if applied to both sides<sup>14</sup>.</p> <p>The pressure exerted on the Letter during automated processing may cause colour offset on digitally printed items. Therefore, it is recommended that there should be no off set of print or colour transfer when the item is exposed to a pressure of 3.43kPa (35g per cm<sup>2</sup>). This equates to a weight of 8.5kg spread over the surface of a DL envelope, and 13.5kg for C5 envelopes.</p>	L <sup>15</sup>
<b>One-Piece Mailer</b>	See One-Piece Mailer Specification (including one-piece mailers, wrap mailers, coupon mailers, feature mailers, Fold & Seal Mailers and machineable postcards) in section 2.7.	-
<b>Perforated Mailers</b>	See Perforated Mail Specification (including perforations, zip tie, and pressure seal envelopes) in section 2.7.2. No other form of perforated mailer is permitted	-
<b>Do Not Redirect</b>	See separate Do Not Redirect Specification	-
<b>Logos &amp; Advertising</b>	<ul style="list-style-type: none"> <li>Any logo or advertising slogan printed on the Letter should not look like a payment indicia or address or include a geographical location, country or a Royal Mail bag or bundle label.</li> </ul>	L <sup>16</sup>

<sup>10</sup> This may result in the unsealed portion of the flap being torn during processing.

<sup>11</sup> This facilitates Mailmark, address, and Indicia reading.

<sup>12</sup> This facilitates the application of codes and artwork to the Letter (i.e. the ink soaks in and does not rub off).

<sup>13</sup> This facilitates the singulation of the mail at machine infeed (i.e. fewer double fed Letters and missorts).

<sup>14</sup> They may have 'window-like characteristics' that reduce mechanical handling capability, increase static cling, and compromise codemark printing.

<sup>15</sup> The impact of this is limited to the artwork and it is highly unlikely to result in poor processing performance.

<sup>16</sup> This will reduce any potential for address reading errors,

Category		Specification Requirement	M/R
Design Cont.	Logos & Advertising Cont.	<ul style="list-style-type: none"> <li>Any graphic outside of the indicia area, which looks like a payment indicia. e.g. stamp, PPI indicia should be avoided.</li> </ul>	L <sup>16</sup>
		<ul style="list-style-type: none"> <li>Slogans where the company name contains the words 'Return', 'Address' and 'Undelivered' should be avoided.</li> </ul>	L <sup>16</sup>
Window	Fixing	<ul style="list-style-type: none"> <li>Envelopes with apertures must have a window film covering the aperture, and the film must be securely sealed to the inside of the envelope on all sides of the aperture.</li> </ul>	M
		<ul style="list-style-type: none"> <li>The Delivery Address must be visible through the window.</li> </ul>	M
		<ul style="list-style-type: none"> <li>The window film should be flat and fixed evenly across the surface area it is in contact with.</li> </ul>	H <sup>17</sup>
		<ul style="list-style-type: none"> <li>The window film should be robust enough not to become creased, crumpled or otherwise deformed.</li> </ul>	H <sup>17</sup>
	Number	There should be no more than 2 windows on the front of the Letter (or alternatively 1 on the front and 1 on the back).	L <sup>18</sup>
	Size	The window(s) on the front of the Letter must take up no more than 50% of the surface area.	M
	Size & Shape	<ul style="list-style-type: none"> <li>Front windows should be rectangular (with rounded corners), or circular and no more than 85mm in diameter (see Figure 6).</li> </ul>	L <sup>17</sup>
		<ul style="list-style-type: none"> <li>Where there are both front and back windows, the back window must be circular. The back window no more than 48mm in diameter and be centred 31mm, plus or minus 2mm up from the bottom edge of the Letter.</li> </ul>	L <sup>17</sup>
Position	<ul style="list-style-type: none"> <li>Windows on the front of the envelope must avoid the indicia area and the codemark clear zones, and must be located at least 15mm from the top, left and right edges, and at least 18mm from the bottom edge. (See Figure 9 - Figure 12)</li> </ul>	M	
	<ul style="list-style-type: none"> <li>Windows on the back of the Letter must be at least 18 mm from the bottom edge of the Letter and be at least 15mm from the edge for the remaining three sides. (See Figure 9 - Figure 12)</li> </ul>	M	
Gloss	The maximum gloss value for the window should not exceed 150 when measured at 60°, in accordance with American Standard Test Method (ASTM) 2457.	H <sup>17</sup>	
Haze	The maximum haze value for the window should not exceed 75% in accordance with (ASTM D1003-00 Procedure A (Hazemeter)).	H <sup>17</sup>	

<sup>17</sup> This ensures that the Letter is strong enough to withstand the rigours of mechanical and manual handling and facilitates Mailmark and address reading.

<sup>18</sup> This facilitates Mailmark and address reading.

### 2.1.1 Mailmark Letters - Labels

Labels may be used for address and/or indicia content and/or Mailmark code content.

Requirements for the location of the indicia, delivery address block, return address block, and Mailmark codes remain as specified in sections **Error! Reference source not found.** - 2.7.

Requirements for Mailmark code quality, clear zones, skew, opacity etc. remain unchanged.

Category		Specification Requirement	M/R
Physical	Peel adhesion	The peel adhesion strength of the label must be sufficient to ensure that fibre tear is be exhibited on separation	M
	Shape	Labels should be rectangular or square and have radiused corners	H <sup>19</sup>
	Opacity	The paper used should be at least 85 % opaque (BS ISO 2471 - Paper and board. Determination of opacity)	H <sup>20</sup>

### 2.2 Mailmark Letters - Indicia

Category		Specification Requirement	M/R
Physical	General	<ul style="list-style-type: none"> <li>All Letters must carry an approved Indicia which has been agreed by Royal Mail and the customer.</li> <li>Only one Indicia must be printed on the Letter.</li> </ul>	M
			M
	Location	The Indicium must be located on the front of the Letter, above and to the right of the Delivery Address and in the top right corner of the Letter in the Indicium area. This area is 75mm long (103mm long when PPI Designs 3 & 4 are used) & 40mm high	M
Digital Stamp		See Digital Stamp Specification.	-

<sup>19</sup> This facilitates address reading and optimises label adhesion.

<sup>20</sup> This facilitates Mailmark, address, and Indicia reading.

## 2.4 Mailmark Letters – Addressing

In this section, Mandatory requirements ensure that sufficient address content is provided to enable Royal Mail to read the address, and to deliver the Letters to the correct address. Recommended requirements enable effective processing when Letters cannot be processed against a Mailmark code.

Category		Specification Requirement	M/R
Delivery Address	Delivery Address Elements	Mailer Defined Information DF 100 (if required) Addressee MS A N Other ] Organisation Royal Mail ] Delivery Thoroughfare 185 Farringdon Road ] Address Locality London ] block Postcode EC1A 1AA ]	M
	General	<ul style="list-style-type: none"> <li>Only one Delivery Address must be printed on the Letter.</li> <li>The Delivery Address must be printed on the front of the Letter, on the same side and in the same orientation as the Indicia.</li> <li>No other addresses and nothing else that can be construed as looking like a Delivery Address must be printed on the Letter (with the exception of the Return Address).</li> <li>A maximum of 2 lines of addressee information may be included above the PAF address. This may be included in English, Welsh, or bi-lingual English / Welsh.</li> <li>Bi-lingual address content is not acceptable. e.g. Abertawe or Swansea may be used but NOT Abertawe Swansea. The Delivery Address may include a Welsh language alternative where the Welsh alternative is included in PAF. e.g. Abertawe may be used as an alternative to Swansea.</li> </ul>	M M M M M
	Mailer Defined Information (Optional)	<ul style="list-style-type: none"> <li>Mailer Defined Information (MDI) may optionally be included as an additional single line immediately above the addressee's name. It must not include a barcode of any kind.</li> <li>The mailer defined information should be in a typeface (not underlined) and may comprise letters, numerals, punctuation marks, and ideograms in a single line above the addressee e.g. a reference number or Standard Selection Code (SSC).</li> <li>The mailer defined information should be left justified and aligned to the rest of the Delivery Address block.</li> <li>The content may be of a different font and size to the other Delivery Address block elements.</li> <li>The line spacing should be consistent with the rest of the Delivery Address block.</li> <li>The length of the mailer defined information should not exceed 64 characters.</li> </ul>	M L L L L L
	Content	<ul style="list-style-type: none"> <li>The Delivery Address must be a current PAF address that includes at least one premise element, one thoroughfare element, one locality element <sup>21</sup>, and the postcode.</li> <li>A maximum of 2 lines of addressee information may be included above the PAF address.</li> <li>The number of characters per line of the delivery address block should not exceed 64 characters (including spaces).</li> <li>No counties or UK countries should be included within the Delivery Address block.</li> </ul>	M L L L
	Structure & Format	<ul style="list-style-type: none"> <li>The Delivery Address must be provided as a 'block' of left justified text with uniform line spacing (1-4mm) and with no blank lines.</li> <li>Each individual element of the address must be on a separate line. Note that the house number and the street name must always be printed on the same line.</li> <li>The Postcode must always be printed in 'UPPER CASE' and must be on the last line of the Delivery Address.</li> <li>There should be a gap of 1-2 spaces between the 2 parts of the postcode.</li> </ul>	M M M L

<sup>21</sup> Where there is both a locality and a post town in the corresponding PAF record it is recommended that both are included.

Category	Specification Requirement	M/R	
Delivery Address Cont.	Structure & Format Cont.	• The posttown may precede the postcode on the last line of the address if they are separated by 1-2 spaces. i.e. London EC1A 1AA.	L
		• Only punctuation that is included with the PAF address should be included, or alternatively all punctuation may be removed <sup>22</sup> .	L
		• The Delivery Address should be printed in 'Title Case' (preferred) or 'UPPER CASE'.	L
		• The word spacing should be 1-2 spaces and no more than 5mm.	L
		• The Delivery Address block skew should be no more than plus or minus 5°.	L
	Preferred Fonts	• A Single font should be used for the whole Delivery Address block, and this should be printed using : <ul style="list-style-type: none"> <li>○ A minimum of 10-12pt font</li> <li>○ Normal character spacing</li> <li>○ Pitch set at 10-12 characters per inch.</li> </ul>	M
		<p><u>Preferred Non-Proportionally Spaced Fonts are :-</u>  <i>Courier</i>, <i>Courier New</i>, <i>Letter Gothic</i>, <b>Lucida Console</b>,  <b>Lucida Sans Typewriter</b>, <b>OCR B</b>, <i>Word Gothic</i></p> <p><u>Acceptable Proportionally Spaced Fonts are :-</u>  <i>Arial</i>, <i>Avant Garde</i>, <i>Calibri</i>, <b>Estrangelo Edessa</b>, <i>Eurostile</i>, <i>Frankfurt Gothic</i>,  <i>Franklin Gothic (Book)</i>, <i>Gautami</i>, <i>Geneva</i>, <i>Gill Sans</i>, <i>Helvetica</i>, <i>Latha</i>, <b>Lucida Sans</b>, <b>Mangal</b>, <i>News Gothic MT</i>, <i>Optima</i>, <i>Ravi</i>, <i>Shruti</i>, <i>Trebuchet MS</i>,  <i>Tunga</i>, <i>Univers</i>, <i>Verdana</i></p>	L
	Fonts - General	Any fonts that are used should be simple and easy to read. The following recommended specifications should be followed:	H
		• <i>Italic</i> , <b>bold</b> , pseudo script, serifs, computer zero (Ø) and <u>underlining</u> should be avoided.	H
		• There should be clear vertical gaps of at least 0.25mm between extremities of adjacent characters.	H
• Height: 2mm min, 7mm max, Width: 7mm max		H	
• Ratio of lower-case height (b) to 'UPPER CASE' height (a) of between 2:3 and 3:4; and ratio of width (c) to height (a) of approximately 2:3. (See Figure 7)		H	
• Character quality should be complete, clear and of high resolution, with individual stroke having a uniform thickness of 8% - 16% of the height of the character.	H		
Print Quality	• The Delivery Address block MUST be printed using a dark colour (preferably black) on a light background.	M	
	• The paper opacity value should be at least 85 % (BS ISO 2471 - Paper and board. Determination of opacity (paper backing)).	L	
	• The contrast ratio for addresses printed on envelopes should be at least 50 % (window inserts 55%).	L	
	• Print quality should be such that characters are not blurred, smudged, deformed, or incomplete.	L	
	• There should be no splashing or ink spatter around the characters.	L	
	• We recommend that you regularly check the quality of your print output for clarity.	L	
Location	• The Delivery Address block must be positioned on the front of the Letter below and to the left of the Indicia (See Figure 9 - Figure 12)	M	

<sup>22</sup> If commas are used and show in the data files, they may impact the formatting of Mailmark Direct Data files which are in a csv format.

Category		Specification Requirement		M/R
Delivery Address Cont.	Location Cont.	<ul style="list-style-type: none"> <li>The Delivery Address block must not be printed in the Indicia Area. This area is in the top right corner of the Letter and is 75mm long &amp; 40mm high.</li> <li>The Delivery Address block must not be in the border area:                             <ul style="list-style-type: none"> <li>Landscape – Border area is 15mm top 15mm left and right, &amp; 18mm at the bottom,</li> <li>Portrait – 18mm left, 15mm top, right and bottom.</li> </ul> </li> <li>The Mailmark code must be at least 2mm from the Delivery Address block.</li> <li>The Delivery Address block should not be printed over the edge of the envelope flap.</li> <li>With the exception of the Mailmark code, a clear zone of at least 5mm is required around the Delivery Address block (including the MDI). No text, patterning, or graphics should be printed within the Delivery Address block and its clear zones. (See Figure 8).</li> <li>The last line of the Delivery Address block should always be at least 50mm from the top edge of the Letter.</li> <li>The Delivery Address block should not encroach into the tag codemark clear zone. (See section 2.6).</li> </ul>		M
		M		
		L		
H				
L				
L				
Window Clear Zone		Where window envelopes are used, a minimum clear zone of 2mm within the window and 3mm on the envelope should be used. The clear zone requirements apply always, including after the Letter is tapped on all four edges to induce maximum insert movement. i.e. The whole of the PAF Delivery Address should always be visible.		L
Return Address	Return Address Example	Return Address Royal Mail Rowland Hill House Swindon SN3 5TQ	Return Address Royal Mail Rowland Hill House Swindon SN3 5TQ	M
	General	<ul style="list-style-type: none"> <li>Only one return address must be printed on the Letter.</li> <li>Nothing else that looks like a return address must be printed on the Letter.</li> <li>The return address may be printed in English or Welsh (where provided in PAF). The inclusion of return addresses printed in both English and Welsh is not permitted.</li> </ul>		M
		M		
		M		
	Content	<ul style="list-style-type: none"> <li>The return address must be prefixed with the words Return Address in English <sup>23</sup>.</li> <li>The addressee information must be included beneath the Return Address prefix(es).</li> <li>The return address must be a PAF address that includes a premise element, thoroughfare element, locality, and the postcode <sup>24</sup>.</li> <li>Bi-lingual address content is not acceptable. e.g. Abertawe or Swansea may be used but NOT Abertawe Swansea. The Delivery Address may include a Welsh language alternative where the Welsh alternative is included in PAF. e.g. Abertawe may be used as an alternative to Swansea.</li> <li>The number of characters per line of the return address block should not exceed 64 characters (including spaces).</li> <li>No counties or UK countries should be included within the return address block.</li> </ul>		M
		M		
		M		
L				
Structure & Format	<ul style="list-style-type: none"> <li>The return address must be provided as a 'block' of left justified text with uniform line spacing (1-4mm) and with no blank lines.</li> <li>The return address must be printed in 'Title Case', with the exception of the Postcode that must always be printed in 'UPPER CASE'.</li> <li>Each individual element of the address must be on a separate line. Note that the house number and the street must always be printed on the same line.</li> </ul>		M	
	M			
	M			



<sup>23</sup> Cyfeiriad Dychwelyd (the Welsh language Return Address wording) may be printed beneath words Return Address.

<sup>24</sup> Freepost Name addresses are not acceptable as a Return Address.

Category		Specification Requirement	M/R
Return Address	Structure & Format Cont.	<ul style="list-style-type: none"> <li>The Postcode must be printed on the last line of the address or may be printed on the same line as the posttown (with a gap of 1-2 spaces).</li> </ul>	M
		<ul style="list-style-type: none"> <li>Only punctuation that is included with the PAF address must be included, or alternatively all punctuation may be removed.</li> </ul>	M
		<ul style="list-style-type: none"> <li>The word spacing must be no more than 5mm.</li> </ul>	M
		<ul style="list-style-type: none"> <li>The return address block skew must be no more than plus or minus 5°.</li> </ul>	M
	Fonts	<ul style="list-style-type: none"> <li>Letter Gothic or Lucida Console font must be used for the whole return address, and this must be printed using:                             <ul style="list-style-type: none"> <li>10-12pt font (12pt preferred)</li> <li>Normal character spacing</li> <li>Pitch set at 10-12 characters per inch</li> </ul> </li> </ul>	M
		<ul style="list-style-type: none"> <li>Italic, bold, pseudo script, serifs, computer zero (Ø) and underlining must not be used.</li> </ul>	M
Print Quality	<ul style="list-style-type: none"> <li>The same specifications which apply to the Delivery Address must be met.</li> </ul>	M	
	<ul style="list-style-type: none"> <li>The return address block MUST be printed using a dark colour (preferably black) on a light background.</li> </ul>	M	
Location	<p>The return address must within the top 40mm of the mailpiece and may be located :-</p> <ul style="list-style-type: none"> <li>On the back of the Letter and centred. This is the preferred location as it avoids any confusion with the Delivery Address block (See Figure 13) or</li> <li>On the front of the Letter from the top left corner to the left end of the indicia area, with no element closer than 75mm from the right edge and no closer than 12mm to the Delivery Address. (See Figure 14 &amp; Figure 15).</li> </ul>	M	
Clear Zones	<ul style="list-style-type: none"> <li>No text, patterning, or graphics must be printed within the return address area.</li> </ul>	M	
	<ul style="list-style-type: none"> <li>There must be a clear zone of 5mm around the return address.</li> </ul>	M	

## 2.5 Mailmark Letters – Mailmark Code

Category		Specification Requirement	M/R
General	General	<ul style="list-style-type: none"> <li>Only one <b>Mailmark</b> 2D code or 4-state barcode must be printed on the Letter (the only exception being 4-State Consolidator Barcode which may be printed onto Letters that bear another Mailmark code).</li> </ul>	M
		<ul style="list-style-type: none"> <li>The Mailmark 2D code or 4-state barcode content must be aligned to the human readable attributes that are printed on the Letter and be appropriate for the service used.</li> </ul>	M
		<ul style="list-style-type: none"> <li>The Mailmark 2D code or 4-state barcode must always be located on the same side of the envelope as the Indicia and the Delivery Address block.</li> </ul>	M
<ul style="list-style-type: none"> <li>The Mailmark 2D code or 4-state barcode and clear zone must remain visible at all times.</li> </ul>		M	
<ul style="list-style-type: none"> <li>The Mailmark 2D code or 4-state barcode must not be printed over the edge of the envelope flap.</li> </ul>		M	
E Manifest Handling Spec	Mailings must meet the requirements of the E Manifest Handling System Customer Upload Specification (process and implementation).	M	
Mailmark Barcode Specific	The Mailmark codes must meet the requirements of Mailmark Barcode Specification (2D & 4-State Code and content definition).	M	
2D Codes	Code Type	<p>You must use a Data Matrix type ECC200 code complying with the international standard ISO/IEC 16022:2006. Formats 7, 9, or 29 may be used.</p> <div style="display: flex; justify-content: space-around; align-items: center;"> <div style="text-align: center;">  <p><b>Format 7</b> (24 x 24 modules)</p> </div> <div style="text-align: center;">  <p><b>Format 9</b> (32 x 32 modules)</p> </div> <div style="text-align: center;">  <p><b>Format 29</b> (16 x 48 modules)</p> </div> </div>	M
	Data Content	The data content must comply with the C40 encodation scheme (Basic Character set - Uppercase Alphas, Numerals and SPACE only) as described within ISO 16022:2006. Full details of the required Mailmark 2D code content is provided in the EIB Barcode Definition Document.	M
	Size & Shape	<ul style="list-style-type: none"> <li>The Mailmark 2D code must have a module size of 0.5 – 0.7mm</li> <li>Every module must be square.</li> <li>The Mailmark 2D Code may be orientated horizontally or vertically but must not be printed with any degree of skew.</li> </ul>	M
	Clear Zone	<ul style="list-style-type: none"> <li>No other text, patterning, or graphics shall be printed in an area around the 2D code that is at least 4 times the module size (i.e. at least 2mm when the module size is 0.5mm, and at least 2.8mm when the module size is 0.7mm).</li> <li>The clear zone requirements apply at all times, including when windows envelopes are used and after the Letter is tapped on all four edges, to induce maximum insert movement i.e. The whole of the 2D code and the Delivery Address block together with their required clear zones must be visible at all times.</li> </ul>	M
Location	<p>The 2D code must not be printed in the Letter border area (See Figure 9 – Figure 12) :-</p> <ul style="list-style-type: none"> <li>Landscape – 15mm top, left and right, and 18mm at the bottom;</li> <li>Portrait – 18mm left, 15mm top, right and bottom;</li> </ul>	M	
	<ul style="list-style-type: none"> <li>The 2D code may encroach into the Indicia area provided sufficient space is left for the indicia and its associated clear zone. (i.e. top right corner (landscape or portrait) in an area 75mm long &amp; 40mm high);</li> </ul>	M	
	<ul style="list-style-type: none"> <li>The 2D code must not be printed in the tag codemark clear zone (i.e. 60mm up from the bottom right corner of the Letter, and 10mm high x 100mm long);</li> </ul>	M	
			M

Category		Specification Requirement	M/R
2D Codes Cont.	Location Cont.	<ul style="list-style-type: none"> <li>Where the address and Mailmark code are printed onto a label, the Mailmark clear zone (including the clear zone to the edge of the label) must be maintained. The Delivery Address clear zone may be limited to 2mm.</li> </ul>	M
	Print Quality	<ul style="list-style-type: none"> <li>The 2D code shall be printed in black on a background that is of consistent contrast by design, with a positive contrast for the symbol (dark on a light background).</li> </ul>	M
		<ul style="list-style-type: none"> <li>The 2D code must be printed to ISO 15415:2011 grades 4(A) or 3(B) when read under white light. Note: A and B are the equivalent ANSI standards understood by American standard users. (A Module size of 0.5mm equates to 6 dots when printed at 300dpi, whilst a module size of 0.7mm equates to 8 dots when printed at 300dpi).</li> </ul>	M
<ul style="list-style-type: none"> <li>No other text, patterning, or graphics shall be printed in the area occupied by the 2D code.</li> <li>Printing or embossing of security backgrounds, if essential, should be faint, of uniform consistency and be on the inside of the envelope.</li> </ul>		M L <sup>25</sup>	
4-State Barcode	Code Type	<p>The 4-State barcode is a barcode that uses 4-State symbology. The data is encoded to produce a barcode that includes bars in 4 possible states - "D" = Descender bar, "A" = Ascender bar, "F" = Full bar, "T" = Track bar (DAFT). Two codes are available:</p> <ul style="list-style-type: none"> <li>Barcode C – Consolidators – 66 bars, and up to 84mm long</li> </ul>  <ul style="list-style-type: none"> <li>Barcode L – High volume Mailers – 78 bars and up to 99mm long.</li> </ul> 	M
	Data Content	The code content must be aligned to the human readable attributes that are printed on the Letter and be appropriate for the product used.	M
	Size & Shape	<ul style="list-style-type: none"> <li>The 4-State barcode must be printed at a pitch of 20-24 bars per 25.4mm.</li> <li>The barcode pitch must be consistent throughout the length of the code.</li> </ul>	M M M
		<ul style="list-style-type: none"> <li>The Ascender and Descender bars are 1.6 to 2.16 mm high; the Track bar is 1.02 to 1.52 mm high, and the bar width is 0.38 to 0.63 mm, with the full bar being 4.22mm to 5.84mm high. The width requirements apply throughout the whole bar. i.e. No part of the bar can be less than 0.38mm wide or greater than 0.63mm wide.</li> </ul>	M
		<ul style="list-style-type: none"> <li>The vertical alignment of the code must be consistent. The track element of the bars must be symmetrical about the centre line of the code, plus or minus 10% of the height of the centre line (see Figure 16).</li> <li>The barcode skew must be less than 5° (see Figure 17 &amp; Figure 18).</li> </ul>	M M
	Code Clear Zone	<ul style="list-style-type: none"> <li>A clear zone of 2mm must be maintained on all four sides of the 4-State barcode.</li> <li>The clear zone requirements apply at all times, including when window envelopes are used and after the mail item is tapped on all four edges, to induce maximum insert movement (i.e. the whole of the 4-State barcode and the address block together with their required clear zones must be visible at all times).</li> </ul>	M M
	Location	<p>The 4-State barcode must not be printed in the border area (See Figure 9 - Figure 12) :-</p> <ul style="list-style-type: none"> <li>Landscape - 15mm top, left and right, and 18mm at the bottom;</li> <li>Portrait - 18mm left, 15mm top, right and bottom;</li> </ul>	M M M
<ul style="list-style-type: none"> <li>The 4-State barcode may encroach into the Indicia area provided sufficient space is left for the indicia and its associated clear zone. (i.e. top right corner (landscape or portrait) in an area 75mm long &amp; 40mm high);</li> </ul>		M	
<ul style="list-style-type: none"> <li>The 4-State barcode must not be printed in the tag codemark clear zone. i.e. 60mm up from the bottom right corner of the Letter, and 10mm high x 100mm long.</li> </ul>		M	

<sup>25</sup> The presence of security backgrounds or embossing may limit 4-State barcode reading performance. Such instances are infrequent.

Category		Specification Requirement	M/R
4-State Barcode Cont.	Location Cont.	<ul style="list-style-type: none"> <li>The 4-State barcode must not be printed over the edge of the envelope flap.</li> </ul>	M
		<ul style="list-style-type: none"> <li>Where the address and Mailmark code are printed onto a label, the Mailmark clear zone (including the clear zone to the edge of the label) must be maintained. The Delivery Address clear zone may be limited to 2mm.</li> </ul>	M
	Print Quality	<ul style="list-style-type: none"> <li>The 4-State barcode must be printed in a contrast medium, typically black bars on a white background.</li> </ul>	M
		<ul style="list-style-type: none"> <li>No other text, patterning, or graphics shall be printed or present in the barcode area and its clear zone (i.e. this may be design graphics or Letter substrate characteristics).</li> </ul>	M
		<ul style="list-style-type: none"> <li>A minimum Print Contrast Ratio (PCR) and a minimum Reflective Difference (RD) must be applied. These values are:                             <ul style="list-style-type: none"> <li>Minimum PCR is 40%</li> <li>Minimum RD is 30%</li> </ul> </li> </ul>	M
		<ul style="list-style-type: none"> <li>The print quality should be consistent throughout the code. i.e. There must be no gaps between printed dots that may be used to print the code.</li> </ul>	H <sup>26</sup>
<ul style="list-style-type: none"> <li>The edges of the 4-State Mailmark barcode should be sharp and clearly defined.</li> </ul>	H <sup>26</sup>		
<ul style="list-style-type: none"> <li>Printing or embossing of security backgrounds, if essential, should be faint, of uniform consistency and be on the inside of the envelope.</li> </ul>	L <sup>25</sup>		

## 2.6 Mailmark Letters – Codemark Clear Zones

These clear zones relate to the typical location of the orange barcodes that are applied to Letters by Royal Mail to facilitate automated Letter processing.

Category	Specification Requirement	M/R
Tag Codemark <sup>27</sup>	The Mailmark code must not be printed in the Tag Codemark clear zone	M
	This is located 60mm up from the bottom right corner of the Letter, and covers an area 10mm high, and 100mm long (from the right edge of the Letter). This area should be free of any text and graphics. (See Figure 9 - Figure 12)	L <sup>28</sup>
Route Codemark <sup>27</sup>	This is in the bottom right corner of the Letter and covers an area 18mm high (from the bottom edge of the Letter), and 130mm long (from the right edge of the Letter). This area should be free of any text and graphics. (See Figure 9 - Figure 12)	L <sup>28</sup>

<sup>26</sup> Ink jet 4-State codemarks that consist of individual dots (rather than a complete bar) may be read. However, any reduction in print quality may limit 4-State barcode reading performance.

<sup>27</sup> Note that windows are not permitted in the codemark areas.

<sup>28</sup> The printing of the codemark may impair the artwork visuals.

## 2.7 Mailmark Letters – Other Physical Requirements

### 2.7.1 Mailmark Letters – One Piece & Paper Wrap Mailers

For the purposes of this document, a One-Piece Mailer is defined as :- ‘A rectangular or square shaped mailpiece made from rectangular or square paper that is folded and sealed. It may be designed to be opened or to enclose an insert. Its unfolded edges are sealed using either inner adhesive spots or a continuous adhesive line.’

This section defines the specific construction characteristics of One-Piece Mailers (including the machineable postcard that is in effect a permanently sealed one-piece mailer). Other physical requirements together with Indicia, addressing and Mailmark requirements remain as standard.

#### 2.7.1.1 Mailmark Letters – One Piece & Paper Wrap Letter Mailers

Physical Reqt	One-Piece Mailer / Paper Wrap	Advertising Paper Wrap Letters
<b>Purpose</b>	This option is a two-fold mailer with permanently sealed sides that provides a one-piece alternative to the traditional envelope. It has a single fold on the (reference) edge on which the mail is processed and a folded opening flap along the top edge of the mailpiece.	This option is a two-fold mailer with permanently sealed sides that provides a one-piece alternative to open or poly-wrapped large letters that are no more than 248mm long. It has a single fold on the (reference) edge on which the mail is processed and a folded opening flap along the top edge of the mailpiece.
<b>Inserts</b>	Only Paper inserts are permitted (H <sup>30</sup> )	
<b>Shape</b>	(M) Rectangular or Square	
<b>Folds</b>	(M) The long edges of the finished mailpiece must be folds, and the short edges and flap must be sealed.	
<b>Reference Edge<sup>29</sup></b>	<ul style="list-style-type: none"> <li>(M) The reference must be a folded edge on the mailpiece</li> <li>(M) For landscape the folded reference edge is the edge beneath the address.</li> <li>(M) For portrait items the reference edge is the longest left edge.</li> <li>(M) For square mailers, the reference edge is the edge beneath the address.</li> </ul>	<ul style="list-style-type: none"> <li>(M) The reference must be a folded edge on the mailpiece</li> <li>(M) For landscape the folded reference edge is the edge beneath the address.</li> <li>(M) For portrait items the reference edge is the longest left edge.</li> </ul>
<b>Dimensions</b>	(M) Minimum and maximum mailpiece dimensions.	(M) Minimum mailpiece dimensions applies and the maximum permitted is 165mm high x 248mm long.
<b>Thickness</b>	(M) Minimum and maximum mailpiece thickness	(M) Minimum mailpiece thickness dimension applies, and the maximum is 3mm.
<b>Max Weight</b>	(M) Minimum and maximum mailpiece weight.	(M) Minimum mailpiece weight & maximum 70g
<b>Paper Weight</b>	(M) Minimum 100gsm	
<b>Flaps</b>	<ul style="list-style-type: none"> <li>(M) The Mailer must include a flap .</li> <li>(M) Flap should be at the top of the mailer and run parallel to the reference edge and may be on the front or back of the mailer.</li> <li>The width of flap width should be 20-40mm. (L<sup>30</sup>)</li> </ul>	
<b>Adhesive Application</b>	Where there are gaps in the continuous seal adhesive application, they should be ideally located at top of the mailer and may be on left and / or the right side and the gaps should be no more than 5-10mm long (H <sup>31</sup> )	

<sup>29</sup> The reference edge is a fold on a particular edge of the Letter, which enables it to be processed through the machines efficiently.

<sup>30</sup> These requirements relate to the designs that have been tested.

<sup>31</sup> This aims to maximise the strength of the side seals, whilst preventing bursting and potential machine input issues.

Physical Reqts	One-Piece Mailer / Paper Wrap	Advertising Paper Wrap Letters
Sealing	<p><b>With Inserts (H<sup>32</sup>)</b>  <b>(M)</b> All unfolded sides (including the flap) must be glued with a <b>continuous seal</b>.</p> <p><b>No Inserts</b>  <b>(M)</b> All unfolded sides (including the flap) must be glued using a spot seal or a continuous seal.</p>	<p><b>(M)</b> All unfolded sides (including the flap) must be glued with a <b>continuous seal</b>.</p>
Peel Adhesion	<p><b>(M)</b> The peel adhesion strength of adhesive must be a minimum of 0.4N or paper fibres and fibre tear must be exhibited on separation.</p>	
Spot Gluing	<ul style="list-style-type: none"> <li>Adhesive spots may be circular or elliptical. (H<sup>30</sup>)</li> <li>Distance between two closest edges of adhesive spots should be no more than 10mm (H<sup>30</sup>)</li> <li>Size of spots should be at least 5mm in diameter / length. (H<sup>30</sup>)</li> <li>Maximum distance from edge of mailpiece should be 5mm, plus or minus 2mm (H<sup>30</sup>) (See Figure 19)</li> </ul>	<p><b>(M)</b> This is not permitted</p>
Continuous Gluing	<p>A minimum 4mm wide sealed to within 3mm of the edge (H<sup>30</sup>) (See Figure 20)</p>	
Finish	<ul style="list-style-type: none"> <li>Matt finish is preferred. (H<sup>33</sup>)</li> <li>Digitally Printed Mail – See Note in section 2.1</li> </ul>	
Clear Zone inside the Letter	<p>It is advised that there is a 10mm clear zone around the inside perimeter clear of print to ensure that the adhesive properties of the adhesive are not impaired. (L<sup>30</sup>)</p>	

<sup>32</sup> Side seals should not fold during processing.

<sup>33</sup> Silk and gloss finished mailpiece are more likely to stick together (i.e. higher double fed mailpieces and missorts).

## 2.7.1.2 Mailmark Letters – Roll Fold Mailers

Physical Reqs	8pp Roll Fold with an opening flap
Purpose	<p>This option is an 8pp Roll Fold mailer with an opening flap along the top edge of the mailpiece <sup>34</sup>.</p>  <p>To date, this is the only roll-fold mailer design that has been tested successfully.</p>
Inserts	(M) No inserts are permitted.
Shape	(M) Rectangular only
Folds	(M) The long edges of the finished mailpiece must be folds, and the short edges and flap must be sealed. There will be four folds including the fold of the opening flap.
Reference Edge	<ul style="list-style-type: none"> <li>(M) The reference must be a folded edge on the mailpiece</li> <li>(M) For landscape items, the folded reference edge is the edge beneath the address.</li> <li>(M) For portrait items, the folded reference edge is the edge to the left of the address and indicia.</li> </ul>
Dimensions	<p>(M) Finished pack: 210mm (long) x 148mm (high)</p> <p>(M) Open pack: 210mm (long) x 620mm (high)</p>
Thickness	(M) Minimum – 0.25mm, Maximum – 1mm
Max Weight	(M) Maximum – 16g
Paper Weight	(M) 130gsm
Flaps	<ul style="list-style-type: none"> <li>(M) The Mailer must include a flap on the front or on the back of the mailer.</li> <li>(M) The width of flap width must be 40mm.</li> <li>(M) The flap must be at the top of the mailer on the opposite side to the reference edge :- <ul style="list-style-type: none"> <li>For landscape items, the flap is on the edge above the address.</li> <li>For portrait items, the flap is the edge to the right of the address and indicia.</li> </ul> </li> </ul>
Adhesive Application	Where there are gaps in the continuous seal adhesive application, they should be ideally located at top of the mailer and may be on left and / or the right side and the gaps should be no more than 5-10mm long (H <sup>35</sup> )
Sealing	(M) All unfolded sides (including the flap) must be glued using a continuous strip of adhesive.
Peel Adhesion	(M) The peel adhesion strength of adhesive must be a minimum of 0.4N or paper fibres and fibre tear must be exhibited on separation.
Spot Gluing	(M) This is not permitted
Continuous Gluing	(M) A minimum 13mm wide strip of adhesive sealed to the edge
Finish	<ul style="list-style-type: none"> <li>Matt finish is preferred, but silk is acceptable (H)</li> </ul> <p>Digitally Printed Mail – See Note in section 2.1</p>

<sup>34</sup> Note that the illustration below does NOT include the flap.

<sup>35</sup> This aims to maximise the strength of the side seals, whilst preventing bursting and potential machine input issues.

### 2.7.1.3 Mailmark Letter - Feature & Coupon Mailers

Physical Reqs	Feature One-Piece Mailer	Coupon One-Piece Mailer
<b>Purpose</b>	<p>This mailer is specifically designed to open out easily into a full-page feature or a 4pp piece of mail that is not damaged by fibre tear because of adhesive.</p> <p>It has a single fold on the bottom (reference) edge on which the mail is processed, and the three remaining edges are sealed.</p> <p><b>(M)</b> The adhesive must be strong to ensure that the Mailer remains sealed during processing and delivery.</p>	<p>This mailer is specifically designed to provide a pocket in which a small booklet or coupons can be inserted.</p> <p>It has a single fold on the bottom edge and a folded opening flap along the top edge of the mailpiece. The inserts are fixed within the mailer. (See Figure 23.)</p>
<b>Inserts</b>	<p><b>(M)</b> No Insert is permitted</p>	<ul style="list-style-type: none"> <li>• <b>(M)</b> The booklet must be paper only.</li> <li>• <b>(M)</b> The booklet must rest on the reference edge (the longest edge opposite the Indicia)</li> <li>• <b>(M)</b> The booklet must be affixed to the inside the mailer to prevent movement during processing.</li> <li>• The booklet insert should be no more than 85mm x 130mm in size and the mailer should be no more than 2mm thick <b>(H<sup>36</sup>)</b></li> </ul>
<b>Shape</b>	<p><b>(M)</b> Rectangular or Square</p>	<p><b>(M)</b> Rectangular only</p>
<b>Folds</b>	<p><b>(M)</b> Maximum 1 fold</p>	<p>Folded three times to produce a pocket as follows <b>(L<sup>36</sup>)</b> :-</p> <p>Fold 1 - 70mm from bottom edge.</p> <p>Fold 2 - 215mm from bottom.</p> <p>Fold 3 - 360mm from bottom</p>
<b>Reference Edge<sup>37</sup></b>	<ul style="list-style-type: none"> <li>• <b>(M)</b> The reference must be a folded edge on the mailpiece</li> <li>• <b>(M)</b> For landscape the folded reference edge is the edge beneath the address.</li> <li>• <b>(M)</b> For portrait items the reference edge is the longest left edge.</li> <li>• <b>(M)</b> For square mailers, the reference edge is the edge beneath the address.</li> </ul>	<ul style="list-style-type: none"> <li>• <b>(M)</b> Must be a folded edge.</li> <li>• <b>(M)</b> For landscape this is the longest edge beneath the address.</li> <li>• <b>(M)</b> For portrait items this is the longest left edge.</li> </ul>
<b>Dimensions</b>	<p><b>(M)</b> Minimum and maximum mailpiece dimensions</p> <p><b>(M)</b> The front and the back of the mailer must be of equal size.</p>	<p>165mm (L) plus or minus 5mm x 145mm (H) plus or minus 5mm. <b>(L<sup>36</sup>)</b></p>
<b>Thickness</b>	<p><b>(M)</b> Minimum and maximum mailpiece thickness</p>	<p>Minimum mailpiece thickness &amp; Maximum 2mm including insert. <b>(H<sup>38</sup>)</b></p>
<b>Max weight</b>	<p><b>(M)</b> Minimum and maximum mailpiece weight.</p>	<p>No more than 20g <b>(L<sup>36</sup>)</b></p>
<b>Paper Weight</b>	<p><b>(M)</b> 150gsm - 190gsm</p>	<p><b>(M)</b> Minimum 115gsm<sup>39</sup></p>
<b>Paper Thickness</b>	<p>0.13mm - 0.175mm <b>(H<sup>36</sup>)</b></p>	<p>Not applicable</p>

<sup>36</sup> These requirements relate to the designs that have been tested.

<sup>37</sup> The reference edge is a fold on a particular edge of the Letter, which enables it to be processed through the machines efficiently.

<sup>38</sup> This enables effective presentation to the machine and subsequent processing.

<sup>39</sup> Stronger adhesives should be considered where the minimum paper weight is exceeded.

Physical Reqs	Feature One-Piece Mailer	Coupon One-Piece Mailer
Flaps	Not applicable	<ul style="list-style-type: none"> <li>• (M) The Mailer must include a flap</li> <li>• Fold 3 forms a sealing flap 35mm deep at the bottom of the mailer. (L 36)</li> </ul>
Adhesive Application	Where there are gaps in the continuous seal adhesive application, they should be ideally located at top of the mailer and may be on left and / or the right side and the gaps should be no more than 5-10mm long (H 40)	
Sealing	(M) All unfolded sides must be glued using a hot melt spot or continuous seal	(M) All unfolded sides must be glued with a continuous seal.
Peel Adhesion	<ul style="list-style-type: none"> <li>• (M) The peel adhesion strength of adhesive must be a minimum of 0.2N on the sides.</li> <li>• (M) The peel adhesion strength of adhesive must be a minimum 0.25N on the long edge.</li> </ul>	<ul style="list-style-type: none"> <li>• (M) The peel adhesion strength of adhesive used for the side seals must be a minimum of 0.25N and fibre tear must be exhibited on separation.</li> <li>• (M) The peel adhesion strength of the flap must be minimum 0.2N and fibre tear must be exhibited on separation.</li> </ul>
Spot Gluing	<ul style="list-style-type: none"> <li>• Adhesive spots may be circular or elliptical.</li> <li>• Side spots should be at least 11mm in diameter and should be no more than 25mm apart. (H 41)</li> <li>• Long edge spots be at least 15mm in diameter / length and should be no more than 45mm apart. (H 41)</li> <li>• Maximum distance from edge of mailpiece should be 5mm, plus or minus 2mm (H 41) (See Figure 21)</li> </ul>	Not applicable
Continuous Gluing	Not applicable	<ul style="list-style-type: none"> <li>• Continuous 10mm band of adhesive to the side edges of the mailer. (H 41)</li> <li>• Long edge of flap sealed with 6mm-9mm wide line of adhesive or 2 lines of 2mm-3mm wide adhesive that are 2mm-3mm apart. (H 41)</li> <li>• (M) The adhesive must be no more than 5mm from the edge of the flap.</li> <li>• The sides of the flap should be sealed to the edge of the mailpiece with 6mm-9mm wide line of adhesive or 2 lines of 2mm-3mm wide adhesive that are 2mm-3mm apart. (H 41) (See Figure 22.)</li> </ul>
Finish	<ul style="list-style-type: none"> <li>• Matt finish is preferred. (H 42)</li> <li>• Digitally Printed Mail – See Note in section 2.1</li> </ul>	

<sup>40</sup> This aims to maximise the strength of the side seals, whilst preventing bursting and potential machine input issues.

<sup>41</sup> These requirements relate to the designs that have been tested.

<sup>42</sup> Silk and gloss finished mailpiece are more likely to stick together (i.e. higher double fed mailpieces and missorts).

### 2.7.1.4 Mailmark Letters – Machineable Postcard

Category	Specification Requirement	M/R
Machineable Postcard	<p><b>Purpose</b></p> <p>This mailer is specifically designed to provide a postcard of 2/3 ply <sup>43</sup>. The mailer is not designed to be opened.</p> <p>The 3-Ply element provides a reference edge for the mailer, and the varied thickness ensures the items do not stick together.</p> <p>Two physical design options are available :-</p> <ol style="list-style-type: none"> <li>1. The 3-ply paper must be cut finished so all three layers form a single bottom (reference) edge. i.e. the edge consists of 3 layers of paper and 2 layers of adhesive. The finished cut edge must look as if it is a single edge. (See Figure 24)</li> <li>2. The paper must be folded such that the first fold creates an internal flap. The second fold must form another flap that covers the internal flap and ends 1mm short of the bottom (reference) edge. (See Figure 25)</li> </ol>	
	<p><b>Design</b></p> <p>The card must be produced from a sheet of paper that is cut, folded twice, and sealed on all sides. This shall provide a rectangular finished mailpiece in landscape orientation.</p>	M
	<p><b>Inserts</b></p> <p>No Insert is permitted</p>	M
	<p><b>Shape</b></p> <p>As specified below</p>	M
	<p><b>Folds</b></p> <p>The bottom of the finished mailpiece must have a 3-Ply paper thickness amounts to 45% of the height of the shorter edge of the finished mailpiece, whilst the top amounts to 55% of the height of the shorter edge of the finished mailpiece, (a manufacturing tolerance of plus or minus 2mm is permitted).</p>	M
	<p><b>Reference Edge</b> <sup>44</sup></p> <p>Must be a folded edge. (For landscape this is the longest edge beneath the address, and for portrait items this is the longest left edge.)</p>	M
	<p><b>Dimensions</b></p> <p>Minimum and maximum mailpiece dimensions.</p>	M
	<p><b>Max weight</b></p> <p>Minimum &amp; maximum mailpiece weight</p>	M
	<p><b>Paper Weight</b></p> <p>120gsm – 150gsm (150gsm recommended)</p>	M
	<p><b>Paper Thickness</b></p> <p>2-Ply element minimum 0.18mm 3-Ply element minimum 0.27mm</p>	M
	<p><b>Sealing</b></p> <p>All unfolded sides must be glued with a <b>continuous seal</b>. This mailer is not designed to be opened.</p>	M
	<p><b>Peel Adhesion</b></p> <p>The peel adhesion strength of adhesive must be a minimum of 0.4N and fibre tear must be exhibited on separation.</p>	M
	<p><b>Continuous Gluing</b></p> <p>A permanent and continuous adhesive seal of 15mm width to the side edges of the mailer is required on both open sides of the mailpiece and on the internal flap.</p>	M
<p><b>Finish</b></p> <ul style="list-style-type: none"> <li>• Finish – Matt or Silk (Matt preferred)</li> <li>• Digitally Printed Mail – See Note in section 2.1</li> </ul>	H <sup>45</sup>	

<sup>43</sup> The bottom of the finished mailpiece must have a 3-Ply paper thickness, whilst the top must have a 2-Ply thickness.

<sup>44</sup> The reference edge is a fold on a particular edge of the Letter, which enables it to be processed through the machines efficiently.

<sup>45</sup> Silk and gloss finished mailpiece are more likely to stick together (i.e. higher double fed mailpieces and missorts).

## 2.7.2 Mailmark Letters - Perforated Mail - Requirements

For the purposes of this document, a Perforated Mailer is defined as :- 'A Letter that is designed to be wholly or partly opened by tearing off a perforated strip.'

The following design variations are available :-

1. Tamper Evident - Roulette Perforated Mailer – opened by tearing off 3 perforation sides and designed to be tamper evident.
2. Tamper Evident - Pressure Seal Perforated Mailer – opened by tearing off a perforated strip and designed to be tamper evident.
3. Fold & Seal Mailer – this is a one page, folded, sealed mailpiece design with a perforated flap that is designed to open to give access to printed content inside.
4. Fold & Seal Mailer with Coupon – this is a one page, folded, sealed mailpiece design with a perforated flap that is designed to open to give access to printed content inside.
5. Zip Tie Perforations – opened by tearing off a single 'zip strip'.

This section defines the specific construction characteristics of Perforated Letter Mailers. Other physical requirements together with Indicia, addressing and Mailmark requirements remain as standard. No other forms of perforated mail designs are permitted.

### 2.7.2.1 Mailmark Letters - Tamper Evident - Roulette Perforated Mailer

This is opened by tearing off 3 perforation sides and designed to be tamper evident.

Category		Specification Requirement	M/R
Tamper Evident - Roulette Perforated Mailer	Definition	<p>These perforations consist of a line of cuts (holes) and paper bridges in the Letter. Access to the Letter content is gained by tearing the Letter along the line of perforations.</p> 	
	Orientation	The mailpiece must be in either landscape or portrait orientation (but not square).	H
	Design	<ul style="list-style-type: none"> <li>• Inserts are not permitted.</li> </ul>	M
		<ul style="list-style-type: none"> <li>• The perforations should be located on both 'short' sides of the mailpiece, and on one of the long sides of the mailpiece. i.e. only 3 sides may be perforated.</li> </ul>	H
		<ul style="list-style-type: none"> <li>• The perforations should be inset from the edge of the mailpiece by 12mm, plus or minus 1mm.</li> </ul>	H
		<ul style="list-style-type: none"> <li>• The 'short' side perforations should extend to each edge of the envelope.</li> <li>• The 'long' side perforation should not extend beyond the 'short' side perforations.</li> <li>• The indicia should not be printed over the perforations, but the Indicia clear zone may extend into the perforated border.</li> </ul>	H
<ul style="list-style-type: none"> <li>• No other colour should be visible through the perforations that are in the Tag and Route codemark Clear Zones.</li> </ul>	H		
	The above requirements are illustrated in Figure 26 and Figure 27.	H	
Paper Weight	Minimum 100gsm.	M	
Cuts & Bridges	<ul style="list-style-type: none"> <li>• The perforations must be robust enough to remain intact during processing</li> </ul>	M	
	<ul style="list-style-type: none"> <li>• The perforations should be die cut into the mailpiece.</li> </ul>	H	

Category		Specification Requirement	M/R
Roulette Perforated Mailer Cont.	Cuts & Bridges Cont.	<ul style="list-style-type: none"> <li>The cut of the short side perforations should be set at 1.3mm – 2mm long, with a bridge of at least 0.8mm (see Figure 28).</li> </ul>	H
		<ul style="list-style-type: none"> <li>The cut of the long side perforation should be set at 0.5mm – 1.4mm long, with a bridge of at least 0.4mm (see Figure 28).</li> </ul>	H
		<ul style="list-style-type: none"> <li>The cuts should be rectangular in shape and have a width of no more than 0.1mm.</li> </ul>	H
		<ul style="list-style-type: none"> <li>Each cut should be of uniform size and each bridge should be of uniform size.</li> </ul>	H
	Sealing	<ul style="list-style-type: none"> <li>The perforated edges must be securely sealed all round from the perforation to the letter edges.</li> <li>The peak peel adhesion strength of the adhesive should be at least 4.5N, and fibre tear should be exhibited on separation.</li> </ul>	M H

### 2.7.2.2 Mailmark Letters - Tamper Evident - Pressure Seal Perforated Mailer

This is opened by opened by tearing off a perforated strip and designed to be tamper evident.

Category		Specification Requirement	M/R
Tamper Evident - Pressure Seal Perforated Mailer	Definition	<p>This form of Letter has roulette perforations through all layers in a perforated strip on the short sides of the Letter, and a roulette perforation tear off strip on the back. i.e. The short side perforations go through the 3 layers on DL size Letters and through the 2 layers on C5 size Letters. It is produced from a single sheet of paper and designed to be opened by removing the short edge perforated strips first; then removing the tear off strip on the reverse of the mailer to access the content.</p> 	
	Orientation	The Letter should be in either landscape or portrait orientation (square letters are not acceptable).	H
	Design	<ul style="list-style-type: none"> <li>Inserts are not permitted.</li> </ul>	M
		<ul style="list-style-type: none"> <li>The perforations should be located on both 'short' sides of the Letter (i.e. the perforated strip), with the roulette tear strip being on the back of the Letter.</li> </ul>	H
		<ul style="list-style-type: none"> <li>The long edge furthest from the indicia (bottom side on Landscape mail and left side on portrait mail) should be a fold.</li> </ul>	H
		<ul style="list-style-type: none"> <li>The perforated strip should be inset from the sides of the Letter by 12mm, plus or minus 1mm (see Figure 29).</li> </ul>	H
<ul style="list-style-type: none"> <li>The perforated strip should extend to each edge of the envelope (see Figure 30).</li> <li>The indicia should not be printed over the perforations, but the Indicia clear zone may extend into the perforated border.</li> <li>Only one roulette tear strip should be on each Letter.</li> <li>The roulette tear strip should be at least 10mm from the long edge of the Letter and should be at least 10mm wide.</li> <li>The roulette tear strip may extend into 'short' side perforations.</li> </ul>		H H H H	
Paper Weight	<ul style="list-style-type: none"> <li>3-ply DL design - Minimum 100gsm, 2-ply C5 design - at least 150gsm.</li> </ul>	M	
Short Edge Perforations	<ul style="list-style-type: none"> <li>The perforations must be robust enough to remain intact during processing</li> <li>The perforations should be die cut into the Letter.</li> <li>The cut of the 'short' side perforations should be set at 1.3 – 2mm long, with a bridge of at least 0.8mm (see Figure 28).</li> </ul>	M H H	

Category		Specification Requirement	M/R
Pressure Seal Perforated Mailer Cont.	Short Edge Perforations Cont.	• The cuts should be rectangular and have a width of no more than 0.1mm.	H
		• Each cut should be of uniform size and each bridge should be of uniform size.	H
	Long Edge Tear Off Strip	• The perforations should be die cut into the Letter.	H
		• The cut of the 'Tear Strip' perforations should up to 3.3mm long, with a bridge of at least 0.6 mm (see Figure 28).	H
		• The cuts should be rectangular and have a width of no more than 0.1mm.	H
		• Each cut should be of uniform size and each bridge should be of uniform size.	H
	Sealing	• The perforated edges must be securely sealed all round from the perforation to the letter edges.	M
		• Where the roulette tear strip may extend into 'short' side Perforations, it should be securely sealed <sup>46</sup> , and the sealed edge between the roulette tear strip and the edge of the Letter should be securely sealed along its entire length (including the part that extends into the perforated area).	H
		• The peak peel adhesion strength of the adhesive should be at least 4.5N, and fibre tear should be exhibited on separation.	H

### 2.7.2.3 Mailmark Letters – Fold & Seal Mailer (No Coupon)

This section defines the specific construction characteristics of the Fold & Seal mailer. This is a one page, folded, sealed mailpiece design with a perforated flap that is designed to open to give access to printed content inside.

Other physical requirements together with Indicia, addressing and Mailmark requirements remain as standard.

Category		Specification Requirement	M/R
Size & Shape	Shape	Rectangular with straight sides and 90° corners	M
	Orientation	Landscape only	M
	Size <sup>47</sup>	Unfolded Pack - 297mm x 210mm Finished Pack -144mm high x 210mm long (see Figure 32)	M
	Thickness	At the flap - 0.41mm, Elsewhere - 0.28mm	M
	Content	No inserts of any kind are permitted	M
Mailer Construction & Design	Design Options	• The pack is constructed from a sheet of A4 which has been folded twice to create the finished mailer. The first fold must be at 129mm, and the second at 273mm (leaving the flap 24mm deep). (See Figure 33)	M
		• Folds 1 & 2 must be perforated, perforations to meet the cut and bridge requirements detailed in this section.	M
		• There must be no open apertures or windows in the mailer.	M
		• The flap must be fully sealed as is not intended to be opened	M
		• There are 3 variations of this design (see Figure 34) :- 1. Back perforated opener with Bottom Front Flap (Mailer with perforations on reverse and flap on the front at the bottom.) 2. Perforated opener with Bottom Back Flap (Mailer with perforations on the front and flap on the reverse at the bottom.) 3. Front perforated opener with Top Back Flap (Mailer with perforations on the front and flap on the reverse at the top.)	M

<sup>46</sup> This ensures that the Perforated Strips are totally sealed long their length.

<sup>47</sup> A manufacturing tolerance of plus or minus 2mm is permitted.

Category		Specification Requirement	M/R
Mailer Construct. & Design Cont.	Material <sup>48</sup>	High quality white uncoated grade paper with the following properties :- <ul style="list-style-type: none"> <li>○ Paper weight – 120gsm</li> <li>○ Opacity - 97%</li> <li>○ Thickness - 0.152mm</li> <li>○ Smoothness 230 Bendtsen</li> <li>○ Whiteness - 170 CIE</li> <li>○ Stiffness - 300/170 m/N</li> </ul>	M
	Flap	<ul style="list-style-type: none"> <li>• The Mailer must include a flap <sup>49</sup> (which is not intended to be opened).</li> <li>• The flap must be rectangular, 24mm deep and 210mm wide</li> <li>• The flap must be sealed on all 4 sides (See Figure 33)</li> </ul>	M M M
	Sealing <sup>50</sup>	<ul style="list-style-type: none"> <li>• All edges including the flap must be fully and completely sealed using continuous pressure seal adhesive.</li> <li>• Adhesive must also be applied either side of Fold 2. (See Figure 33)</li> <li>• There must be no gaps in the adhesive or any paper distortion.</li> <li>• The adhesive strip must be 4mm wide and no more than 1.5mm from the edge of the mailpiece to which it has been applied.</li> </ul>	M M M
	Peel Adhesion	<ul style="list-style-type: none"> <li>• Fibre tear must be exhibited on separation.</li> </ul>	M
	Perforations	All perforations must be robust enough to remain intact during processing	M
Perforations	Fold Assist Perforation	Perforations are required along the length of Fold 1 and Fold 2 to facilitate construction :- <ul style="list-style-type: none"> <li>• The perforations must be die cut into the mailpiece.</li> <li>• The cut of the perforations along the top edge of the mailpiece must be no more than 2mm, with a bridge of at least 1mm.</li> <li>• The cut of the perforations along the bottom (Reference edge) of the mailpiece must be no more than 2mm, with a bridge of at least 1.5mm.</li> </ul>	M M M
	Opening Perforation	<ul style="list-style-type: none"> <li>• Perforations are required on the back of design option 1 and on the front of design options 2 &amp; 3.</li> </ul>	M
	Opening Perforation Design	<ul style="list-style-type: none"> <li>• Perforations must be on the short sides and one long side of the mailer. Long edge perforations must open from the bottom edge for design options 1 &amp; 2, and from the top for option 3.</li> <li>• The perforations must be inset from the edge of the mailpiece by 8mm.</li> <li>• The perforated corners of the mailers must be set at an angle of 45<sup>0</sup> to the corner and have a radius of 13mm (see Figure 31).</li> <li>• The indicia must not be printed over the perforations, but the Indicia clear zone may extend into the perforated border.</li> <li>• No other colour must be visible through the perforations that are in the Tag and Route codemark Clear Zones.</li> </ul>	M M M M
	Cuts & Bridges	<ul style="list-style-type: none"> <li>• The perforations must be die cut into the mailpiece.</li> <li>• The cut of the perforations must be no more than 2.25mm, with a bridge of at least 0.5mm.</li> <li>• The cuts should be rectangular in shape and have a width of no more than 0.1mm.</li> <li>• Each cut should be of uniform size and each bridge should be of uniform size.</li> </ul>	M M M M

<sup>48</sup> Sylvamo Preprint S Uncoated paper met this specification in November 2023.

<sup>49</sup> The flap is NOT designed to be opened. It makes the mailer more robust and provides a variation in thickness that facilitates automated processing.

<sup>50</sup> Pressure seal adhesive with 20n T peel adhesive strength applied using Flexo with HF driers has been found to be effective. The peel adhesion strength of the label must be sufficient to ensure that fibre tear is exhibited on separation.

### 2.7.2.4 Mailmark Letters – Fold & Seal Mailer with Coupon

This section defines the specific construction characteristics of the Fold & Seal mailer that includes a perforated tear-off coupon. This is a one page, folded, sealed mailpiece design with a perforated flap that is designed to open to give access to printed content inside.

All edges are permanently sealed and there is a permanently sealed flap. The pack opens out into an A4 size mailer by inset perforations. Other physical requirements together with Indicia, addressing and Mailmark requirements remain as standard.

Category		Specification Requirement	M/R
Size & Shape	Shape	Rectangular with straight sides and 90° corners	M
	Orientation	Landscape only	M
	Size <sup>51</sup>	Unfolded Pack – 297mm x 210mm Finished Pack –144mm high x 210mm long (see Figure 32 & Figure 35)	M
	Thickness	At the flap – 0.41mm, Elsewhere – 0.28mm	M
	Content	No inserts of any kind are permitted	M
Mailer Construction & Design	Design Options <sup>52</sup>	<ul style="list-style-type: none"> <li>The pack is constructed from a sheet of A4 which has been folded twice to create the finished mailer. The first fold must be at 129mm, and the second at 273mm (leaving the flap 24mm deep). (See Figure 35)</li> </ul>	M
		<ul style="list-style-type: none"> <li>Folds 1 &amp; 2 must be perforated, perforations to meet the cut and bridge requirements detailed in this section.</li> </ul>	M
		<ul style="list-style-type: none"> <li>There must be no open apertures or windows in the mailer.</li> </ul>	M
		<ul style="list-style-type: none"> <li>The flap must be fully sealed as is not intended to be opened</li> </ul>	M
		<ul style="list-style-type: none"> <li>There are 2 variations of this design (see Figure 36) :-               <ul style="list-style-type: none"> <li>Version 1 – Back perforated opener with Bottom Front Flap (Mailer with perforations on reverse and flap on the front at the bottom.)</li> <li>Version 2 – Perforated opener with Bottom Back Flap (Mailer with perforations on the front and flap on the reverse at the bottom.)</li> </ul> </li> </ul>	M
Material <sup>53</sup>	High quality white uncoated grade paper with the following properties :- <ul style="list-style-type: none"> <li>Paper weight – 120gsm</li> <li>Smoothness 230 Bendtsen</li> <li>Opacity – 97%</li> <li>Whiteness – 170 CIE</li> <li>Thickness – 0.152mm</li> <li>Stiffness – 300/170 m/N</li> </ul>	M	
Flap	<ul style="list-style-type: none"> <li>The Mailer must include a flap <sup>54</sup> (which is not intended to be opened).</li> </ul>	M	
	<ul style="list-style-type: none"> <li>The flap must be rectangular, 24mm deep and 210mm wide.</li> </ul>	M	
	<ul style="list-style-type: none"> <li>The flap must be sealed on all 4 sides (See Figure 36)</li> </ul>	M	
Sealing <sup>55</sup>	<ul style="list-style-type: none"> <li>All edges including the flap must be fully and completely sealed using continuous pressure seal adhesive. This adhesive will exhibit fibre tear.</li> </ul>	M	
	<ul style="list-style-type: none"> <li>Adhesive must also be applied either side of Fold 2. (See Figure 36)</li> </ul>	M	
	<ul style="list-style-type: none"> <li>There must be no gaps in the adhesive or any paper distortion.</li> </ul>	M	
	<ul style="list-style-type: none"> <li>The adhesive strip must be 4mm wide and no more than 1.5mm from the edge of the mailpiece to which it has been applied.</li> </ul>	M	

<sup>51</sup> A manufacturing tolerance of plus or minus 2mm is permitted.

<sup>52</sup> Coupon perforations for design Version 3 (Long edge perforations must open from the front top edge) have not been approved for Coupon designs.

<sup>53</sup> Sylvamo Preprint S Uncoated paper met this specification in November 2023.

<sup>54</sup> The flap is NOT designed to be opened. It makes the mailer more robust and provides a variation in thickness that facilitates automated processing.

<sup>55</sup> Pressure seal adhesive with 20n T peel adhesive strength applied using Flexo with HF driers has been found to be effective. The peel adhesion strength of the label must be sufficient to ensure that fibre tear is exhibited on separation.

Category		Specification Requirement	M/R
	<b>Peel Adhesion</b>	<ul style="list-style-type: none"> <li>Fibre tear must be exhibited on separation.</li> </ul>	M
<b>Perforations</b>	<b>Perforations</b>	All perforations must be robust enough to remain intact during processing	M
	<b>Fold Assist Perforation</b>	Perforations are required along the length of Fold 1 and Fold 2 to facilitate construction :-	M
		<ul style="list-style-type: none"> <li>The perforations must be die cut into the mailpiece.</li> <li>The cut of the perforations along the top edge of the mailpiece must be no more than 2mm, with a bridge of at least 1mm.</li> <li>The cut of the perforations along the bottom (Reference edge) of the mailpiece must be no more than 2mm, with a bridge of at least 1.5mm.</li> </ul>	M
			M
	<b>Opening Perforation - Design</b>	<ul style="list-style-type: none"> <li>Perforations are required on the short sides and one long side of the mailer to create a 'U-shape'. It must be opened from the long edge (see Figure 37).                             <ul style="list-style-type: none"> <li>Version 1 : Long edge perforations must open from the back bottom edge.</li> <li>Version 2 : Long edge perforations must open from the front bottom edge.</li> </ul> </li> <li>The perforations must be inset from the edge by 8mm on the short sides and 15mm on the long side (see Figure 35).</li> <li>The perforated corners of the mailers must be set at an angle of 45<sup>0</sup> to the corner and have a radius of 13mm.</li> <li>The indicia must not be printed over the perforations, but the Indicia clear zone may extend into the perforated border.</li> <li>No other colour must be visible through the perforations that are in the Tag and Route codemark Clear Zones.</li> </ul>	M
			M
			M
			M
			M
	<b>Opening Perforation - Cuts &amp; Bridges</b>	<ul style="list-style-type: none"> <li>The perforations must be die cut into the mailpiece.</li> <li>The cut of the perforations must be no more than 2.25mm, with a bridge of at least 0.5mm.</li> <li>The cuts should be rectangular in shape and have a width of no more than 0.1mm.</li> <li>Each cut should be of uniform size and each bridge should be of uniform size.</li> </ul>	M
		M	
		M	
		M	
<b>Coupon Perforation</b>	<ul style="list-style-type: none"> <li>Perforations are required on the short sides and one long side of the mailer to create a 'U-shape'. It must be opened from the long edge (see Figure 37).                             <ul style="list-style-type: none"> <li>Version 1 : Long edge perforations must open from the back bottom edge with the Coupon being located in the bottom left corner when viewed from the back.</li> <li>Version 2 : Long edge perforations must open from the front bottom edge with the Coupon being located in the bottom left corner when viewed from the front.</li> </ul> </li> <li>The Coupon perforation must be 150mm long and 70mm high.</li> <li>No other colour must be visible through the perforations that are in the Tag and Route codemark Clear Zones.</li> </ul>	M	
		M	
		M	
<b>Coupon Perforation - Cuts &amp; Bridges</b>	<ul style="list-style-type: none"> <li>The perforations must be die cut into the mailpiece.</li> <li>The cut of the perforations must be no more than 2mm, with a bridge of at least 1mm.</li> <li>The cuts should be rectangular in shape and have a width of no more than 0.1mm.</li> <li>Each cut should be of uniform size and each bridge should be of uniform size.</li> </ul>	M	
		M	
		M	
		M	

### 2.7.2.5 Mailmark Letters - Zip Tie Perforations

This section defines the specific construction characteristics of the Zip Tie Perforations. They provide a means of opening a mailpiece by tearing off a single 'zip strip'.

Other physical requirements together with Indicia, addressing and Mailmark requirements remain as standard.

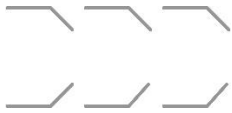
Category	Specification Requirement	M/R
Zip Tie Perforations	<p><b>Definition</b></p> <p>These perforations consist of 2 lines of parallel cuts (holes) and paper bridges in the Letter that form a perforated strip on the flap of the Letter. Access to the Letter content is gained by tearing the strip along the lines of perforations in a particular direction.</p> 	
	<p><b>Orientation</b></p> <p>The mailpiece should be in either landscape or portrait orientation (square letters are not acceptable).</p>	H
	<p><b>Design</b></p> <ul style="list-style-type: none"> <li>All sides of the mailpiece must be folded.</li> <li>The zip tie must be robust enough to remain intact during processing</li> <li>Inserts may be included.</li> <li>The zip tie should always be placed on the back of the mailpiece.</li> <li>The zip tie may be positioned either horizontally or vertically, but the 'Tear' direction of the tie is dependent upon the orientation of the mailpiece. (This is defined in Figure 38 and Figure 39; the orientation and 'Tear' directional requirements relative to position of the Indicia on the front of the Letter being illustrated).</li> <li>The zip tie should be located on a flap that is at least 40mm wide (see Figure 40).</li> <li>The zip tie should be positioned at least 9mm from the edge of the flap (see Figure 40).</li> </ul>	M M H H H H
	<p><b>Paper Weight</b></p> <p>Minimum 150 gsm.</p>	M
	<p><b>Cuts &amp; Bridges <sup>56</sup></b></p> <ul style="list-style-type: none"> <li>The perforations must be robust enough to remain intact during processing</li> <li>Only one zip tie is permitted on each mailpiece.</li> <li>The zip tie should be die cut into the mailpiece.</li> <li>The dimensional requirements for the min bridge and max cut of the zip tie are provided in Figure 41.</li> <li>The cuts should be rectangular and have a width of no more than 0.1mm.</li> <li>All cuts and bridges should be of uniform size.</li> </ul>	M H H H H H
	<p><b>Sealing</b></p> <ul style="list-style-type: none"> <li>The perforated edges must be securely sealed all round from the perforation to the letter edges.</li> <li>The peak peel adhesion strength of the adhesive should be at least 4.5N, and fibre tear should be exhibited on separation.</li> </ul>	M H

<sup>56</sup> Cuts and bridges must be modified as necessary to ensure that they remain robust when heavier papers or inserts are required.

### 2.7.3 Mailmark Letters – Tabbed Mailers

This section defines the specific construction characteristics of Tabbed Mailers. These include mailers that are secured with tabs on either 2 or 3 sides. A folded reference edge is always required. Potential Tabbed mailer designs include :-

- A single sheet folded in half, with a long reference edge and secured with tabs folded over 3 sides.
- A booklet with a long reference edge and secured with tabs folded over 3 sides.
- A multiple folded mailer with folds on both long edges i.e. one long edge creating an opening flap and secured with tabs folded over 2 sides and sealing along the long edge flap.

A minimum of 3 tabs are required, with 5 tabs being required for thicker items.

Other physical requirements together with Indicia, addressing and Mailmark requirements remain as standard.

Category		Specification Requirement	M/R
Physical Mailer	Content / Inserts	<ul style="list-style-type: none"> <li>• Only paper inserts may be included.</li> <li>• The Inserts may be placed in the mailer provided that the insert is no more than 10mm smaller than the mailer length and / or height.</li> </ul>	M H <sup>57</sup>
	Paper Weight	<ul style="list-style-type: none"> <li>• Minimum – 100gsm for multi-fold mailers.</li> <li>• Minimum – 100gsm for booklet outer cover (front and back).</li> <li>• 150gsm minimum for single fold cards.</li> </ul>	M M H <sup>58</sup>
	Reference Edge <sup>59 60</sup>	<ul style="list-style-type: none"> <li>• The reference edge must be a folded edge on the mailpiece.</li> <li>• For landscape items the folded reference edge must be the edge beneath the address.</li> <li>• For portrait items the reference edge must be longest left edge opposite the Indicia.</li> <li>• For square mailers, the reference edge must be edge beneath the delivery address.</li> </ul>	M M M M
	Flexibility	Each Letter must be capable of being transported around a pulley with a radius of 140mm with a max force of 26 N (See Figure 2) <sup>61</sup> . Perfect Bound mailers and content are not acceptable.	M M
	Stitched Spines	Staples that are used to Stich the booklet must be fully pushed through the outer cover and bent flat on the inside.	M
	Windows	Windows are not permitted for tabbed mailers.	M
	Tabs	Shape & Size	<ul style="list-style-type: none"> <li>• Tabs must be rectangular (with rounded corners) or circular.</li> <li>• The minimum diameter / width for the full tab must be no less than 25mm.</li> <li>• Each tab must be folded such that equal proportions of the tab are adhered to the front and back of the mailpiece. e.g. 12mm on the front, 1mm on the edge, and 12mm on the back.</li> </ul>
Material		Tabs made from paper must have a minimum paper weight of 63gsm. Tabs made from polymer must have a minimum weight of 80gsm.	M M

<sup>57</sup> This limits the movement of the insert and any consequent wear on the tab and ensures that the insert cannot fall out.

<sup>58</sup> This is intended to ensure that the Mailer is strong enough to withstand the rigours of mechanical and manual handling. It will also stop other Letters becoming entrapped within the tabbed mailer. Factors including the tab material, size, weight, bridge size and cut together with the mailer weight may all affect the strength of a tabbed mailer. It is strongly recommended that perforated tabs which are considered for use are tested by Royal Mail prior to using our machineable products.

<sup>59</sup> The reference edge is the fold on the longest edge of the Letter, opposite the Indicia, which forms the base of the item, therefore enabling it to be processed through the machines efficiently.

<sup>60</sup> Mailers with 'open' reference edges are NOT machineable.

<sup>61</sup> Letters must be flexible enough to wrap around a cylinder of 280mm diameter without being damaged.

Category		Specification Requirement	M/R
Tabs Cont.	Tear Strength	A tear strength of at least 0.6N is required.	M
	Colour	Tabs must not be luminous.	M
	Perforations	Perforated tabs are acceptable provided that they are strong enough to remain intact during processing and delivery. (Adjustments may be applied if the tabs fail.)	H <sup>58</sup>
	Peel Adhesion	<ul style="list-style-type: none"> <li>The peel adhesion strength of adhesive must be a minimum of 0.2N on the sides.</li> </ul>	M
	Peel Adhesion Cont.	<ul style="list-style-type: none"> <li>The peel adhesion strength of adhesive must be a minimum 0.25N on the long edge.</li> </ul>	M
	Location	<ul style="list-style-type: none"> <li>Tabs must not be applied in the Tag Codemark area that is located 60mm up from the bottom right corner of the Letter, and covers an area 10mm high, and 100mm long (from the right edge of the Letter).</li> <li>Tabs must not be applied in the Route Codemark area that is in the bottom right corner of the Letter and covers an area 18mm high (from the bottom edge of the Letter), and 130mm long (from the right edge of the Letter).</li> </ul>	M
		The Tabs should only be applied in the Letter border area :-	
		<ul style="list-style-type: none"> <li>Landscape - 15mm top, left and right, and 18mm at the bottom;</li> <li>Portrait - 18mm left, 15mm top, right and bottom;</li> </ul>	L <sup>62</sup> L <sup>62</sup>
Tab positioning must ensure that the short side edge from the reference edge to the tab is not open more than 80mm high.		M	
No. of Tabs	A minimum of 1 tab is required to secure each open edge of the mailer. Full details of the requirements for the number of Tabs required together with their locations are provided in the table below.	M	
Gloss	The maximum gloss value for the tabs should not exceed 150 when measured at 60°, in accordance with American Standard Test Method (ASTM) 2457.	H <sup>63</sup>	
Other Physical	One-Piece Mailer	One Piece Mail requirements do not apply to tabbed mailers. This is because the two sets of requirements are independent of each other and considered within this section.	M
	Perforated Mailers	Perforations, Zip strips, pressure seals are not permitted for tabbed mailers.	M
	Do Not Redirect	Do Not Redirect is not permitted for tabbed mailers.	M
Indicia	Location	The Indicum must be located on the front of the Letter, above and to the right of the Delivery Address and in the top right corner of the Letter in the Indicum area. This area is 75mm long & 40mm high (see Figure 42 - Figure 45).  Note that Tabs may be applied within the Indicia area provided that the indicia clear zone requirements are met.	M
	Clear Zone	A clear zone of 5mm, plus or minus 2mm must be provided above, below, and to the right of the Indicia. Where tabs are used, the clear zone requirements must apply between the indicia and the tab.	M
Ret Add	Clear Zones	<ul style="list-style-type: none"> <li>No text, patterning, or graphics must be printed within the return address.</li> <li>There should be a clear zone of 5mm around the return address. Where tabs are used, the clear zone requirements should apply between the Return Address and the tabs.</li> </ul>	M H <sup>64</sup>

<sup>62</sup> This maximises the available space in the Indicia and retains the 'picture frame' around the Mailmark and Address areas.

<sup>63</sup> The reduces potential light reflection that may limit Mailmark reading capability.

<sup>64</sup> This will maintain the ability to read the Return Address

Category		Specification Requirement - Minimum number of tab seals							
Orientation & Height		SHORT EDGE				LONG EDGE			Visual
		Thickness	No. of Tabs	Location <sup>65</sup> <sup>66</sup>	M/R	No. of Tabs	Location	M/R	
Tab Numbers & Location	Landscape (up to 110mm high)	Up to 2mm	1 per side	70mm-80mm up from ref. edge	M	1	Centred with a tolerance of plus or minus 10mm	M	Figure 42
		More than 2mm	1 per side	18mm-35mm up from ref. edge	M	2	Each tab to be 5mm-15mm from each corner	M	Figure 43
	Landscape (up to 90mm high)	Any	1 per side	18mm-35mm up from ref. edge	M	2	Each tab to be 5mm-15mm from each corner	M	Figure 44
	Landscape (More than 110mm high)	Up to 2mm	1 per side	70mm-80mm up from ref. edge	M	2	Each tab to be 5mm-15mm from each corner	M	Figure 44
		More than 2mm	1 per side	70mm-80mm up from ref. edge	M	2	Each tab to be 5mm-15mm from each corner	M	
						2+1	For thicker and heavier mailers an additional tab Centred with a tolerance of plus or minus 10mm	H	
	Portrait (More than 110mm wide)	Up to 2mm	1 per side	70mm-80mm up from ref. edge	M	2	Each tab to be 5mm-15mm from each corner	M	Figure 45
		More than 2mm	1 per side			2+1	For thicker and heavier mailers an additional tab Centred with a tolerance of plus or minus 10mm	H	

<sup>65</sup> The tab must not encroach into the Tag and Route Codemark clear zones.

<sup>66</sup> Tab positioning must ensure that the short side edge from the reference edge to the tab is not open more than 80mm high.

## 2.8 Mailmark Letters - Figures

### 2.8.1 Mailmark Letters - Physical Figures

Figure 1 - Letter Inserts (Not to Scale)

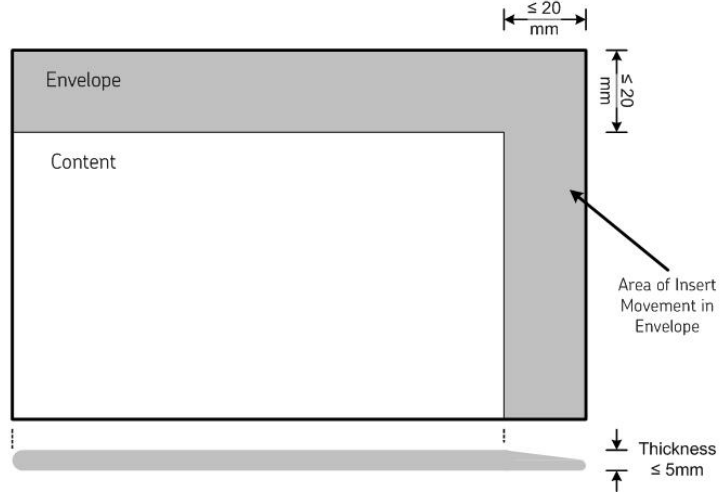

Figure 2 - Letter Flexibility (Not to Scale)

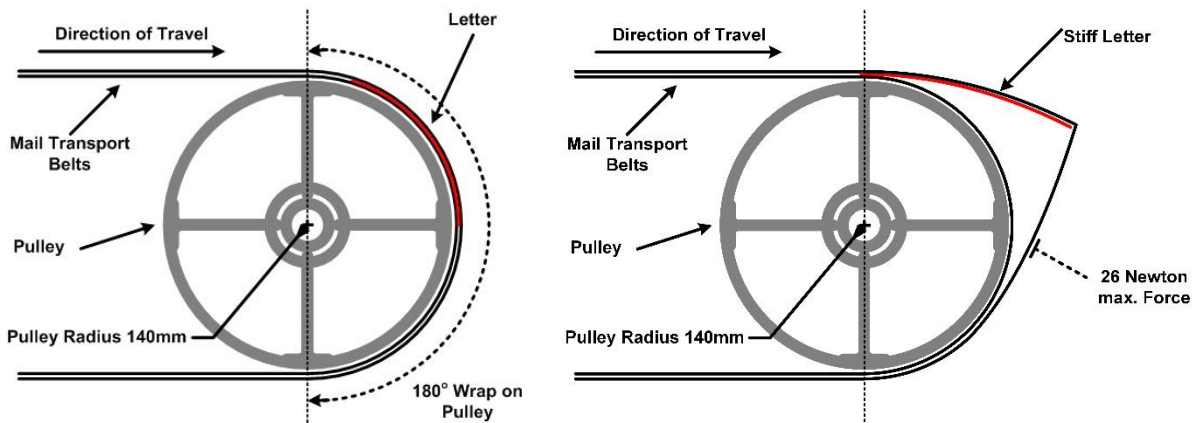

Figure 3 - Reference Edge (Not to Scale)

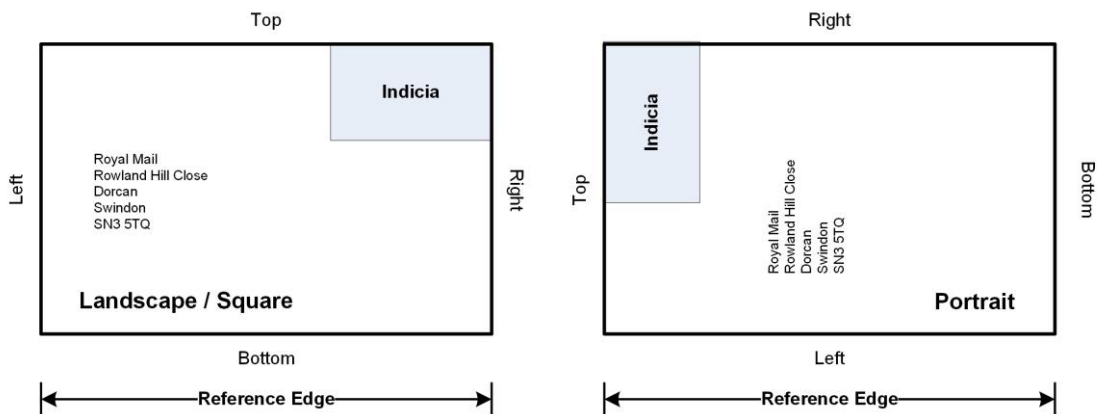

Figure 4 - Letter Sealing - Trayed (Not to Scale)

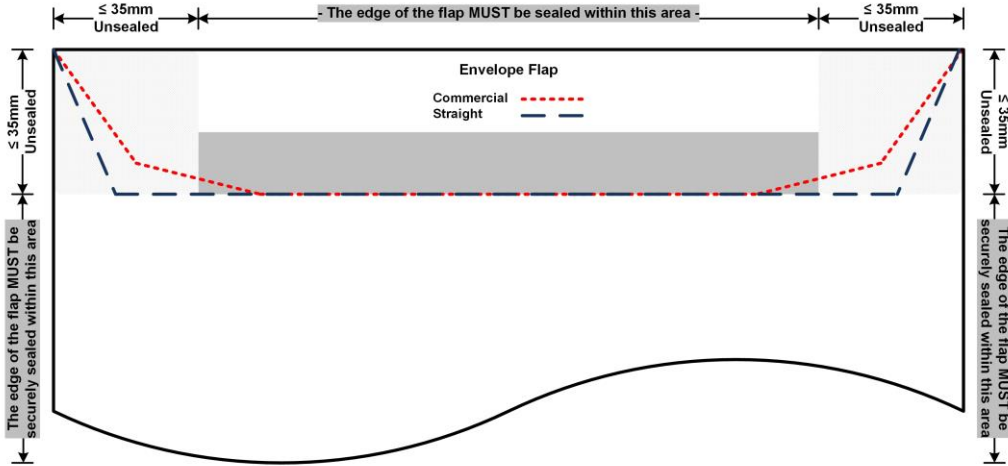

Figure 5 - Letter Sealing - Untrayed (Not to Scale)

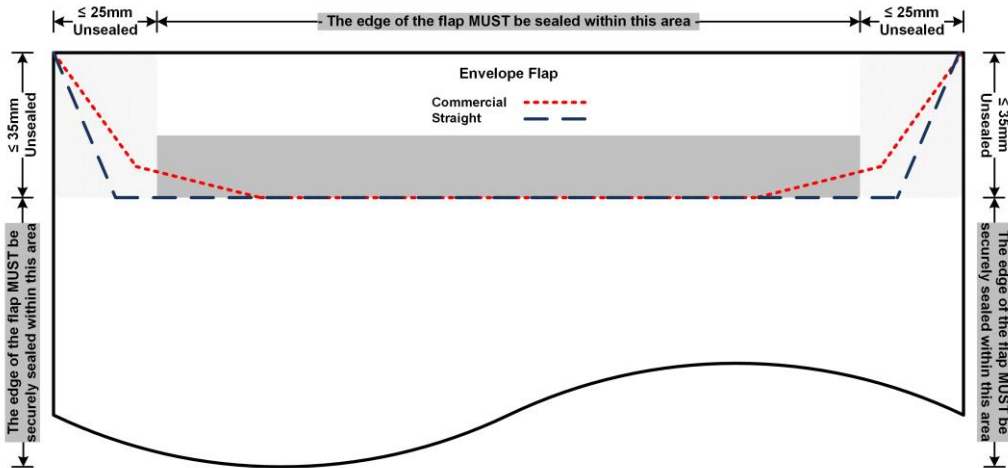
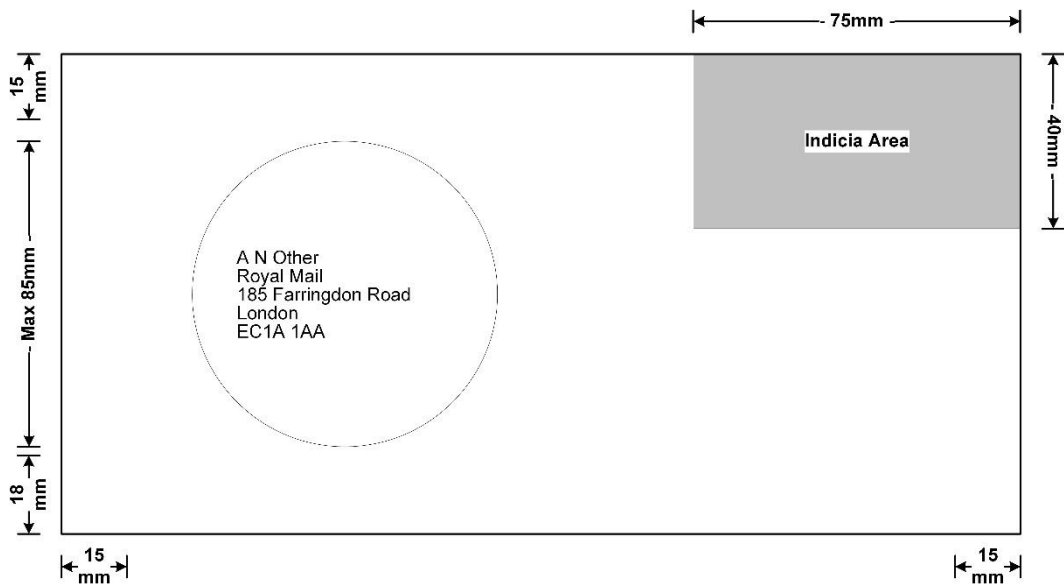

Figure 6 - Back Circular Window (Not to Scale)



## 2.8.2 Mailmark Letters – Addressing Figures

Figure 7 – Letter Font Ratio

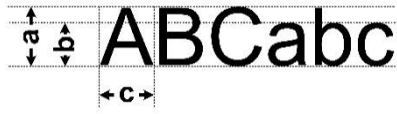

Figure 8 – Delivery Address Block (Not to Scale)

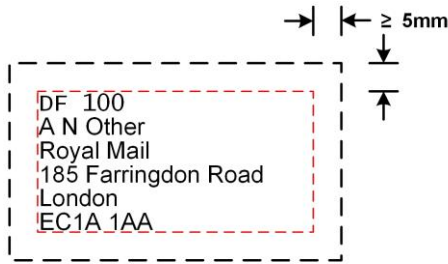

Figure 9 – Letter Clear Zones – Minimum Size (Not to Scale)

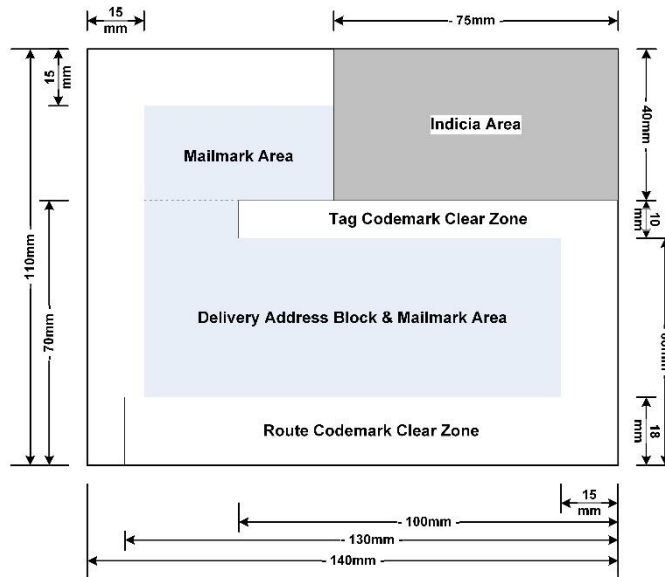

Figure 10 - Letter Clear Zones - DL Envelope (Not to Scale)

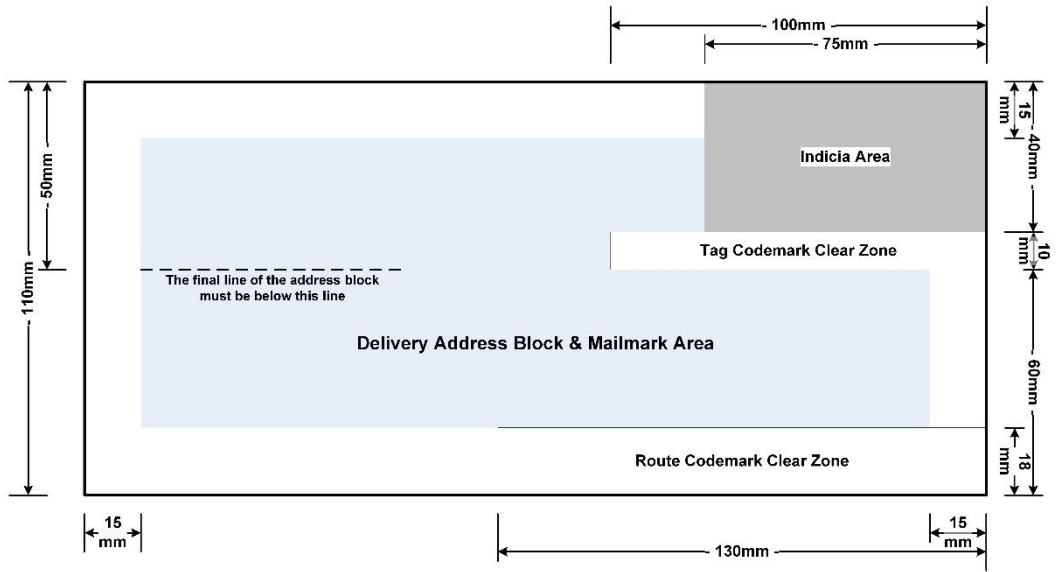

Figure 11 - Letter Clear Zones - Maximum Landscape (Not to Scale)

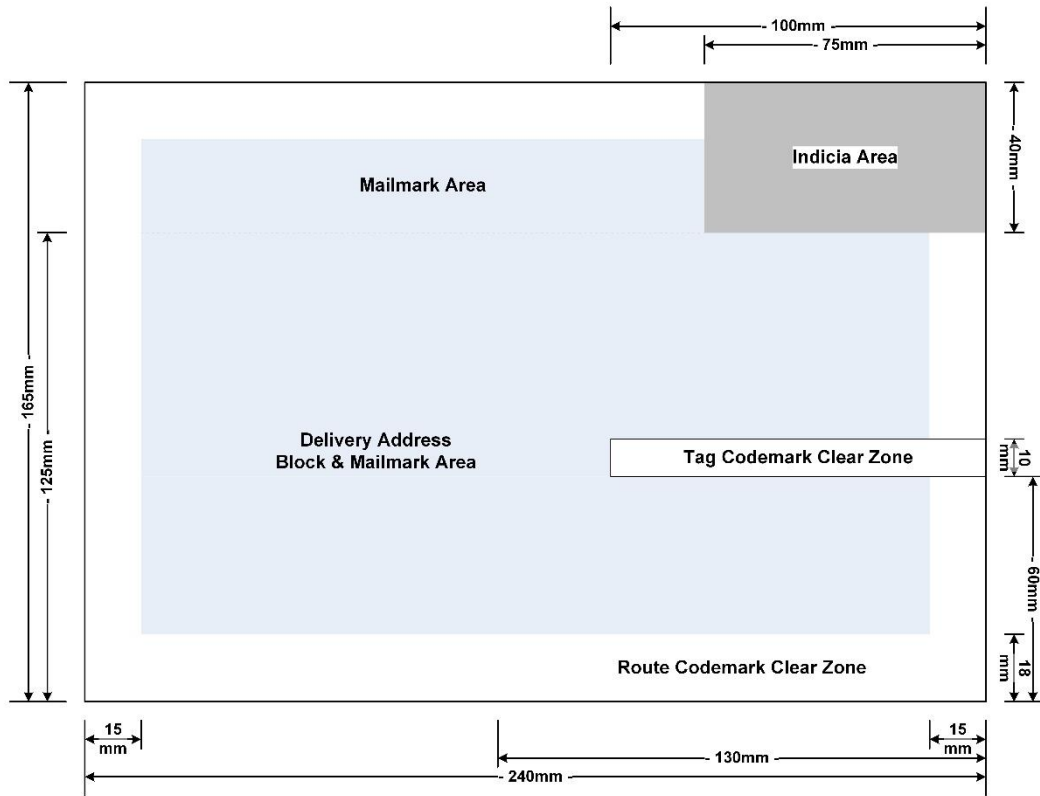

Figure 12 - Letter Clear Zones - Maximum Portrait (Not to Scale)

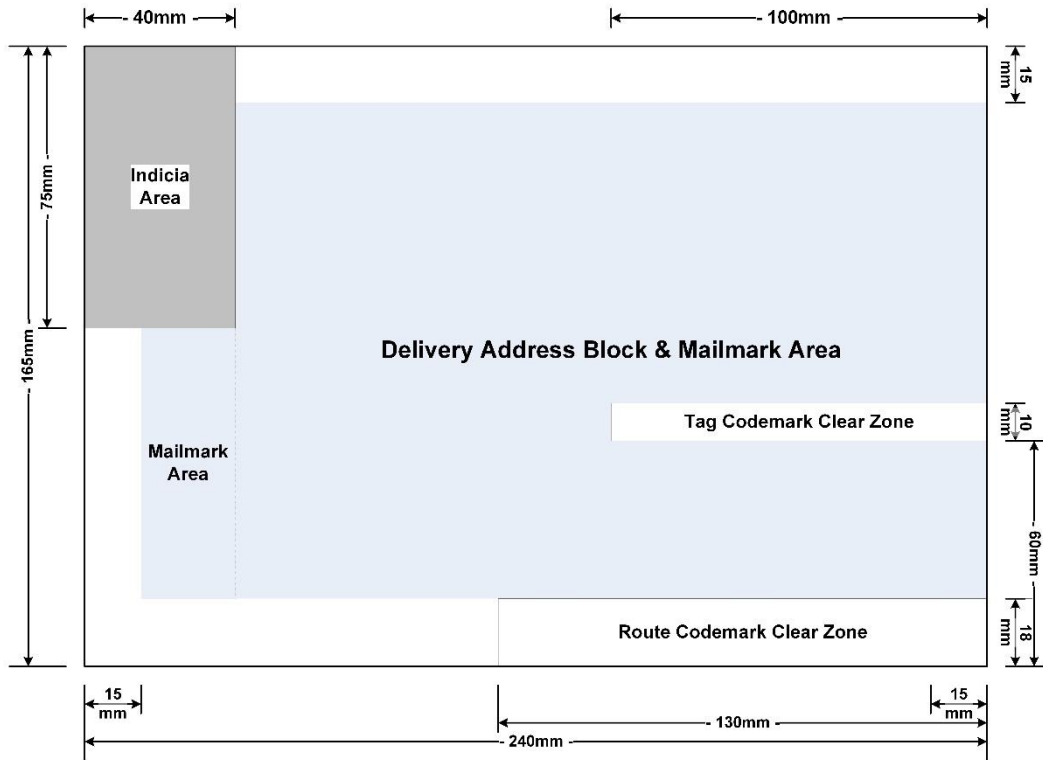

Figure 13 - Letter Return Address Preferred - Back (Not to Scale)

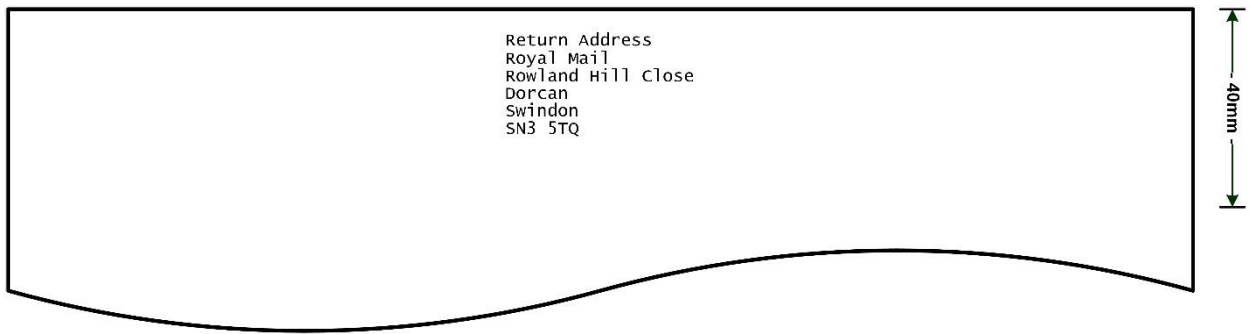

Figure 14 - Letter Return Address - Front Landscape Example A (Not to Scale)

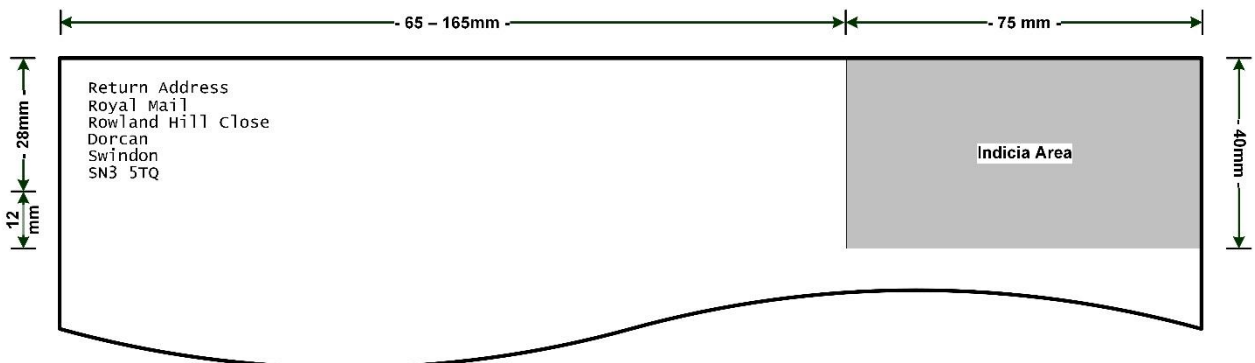
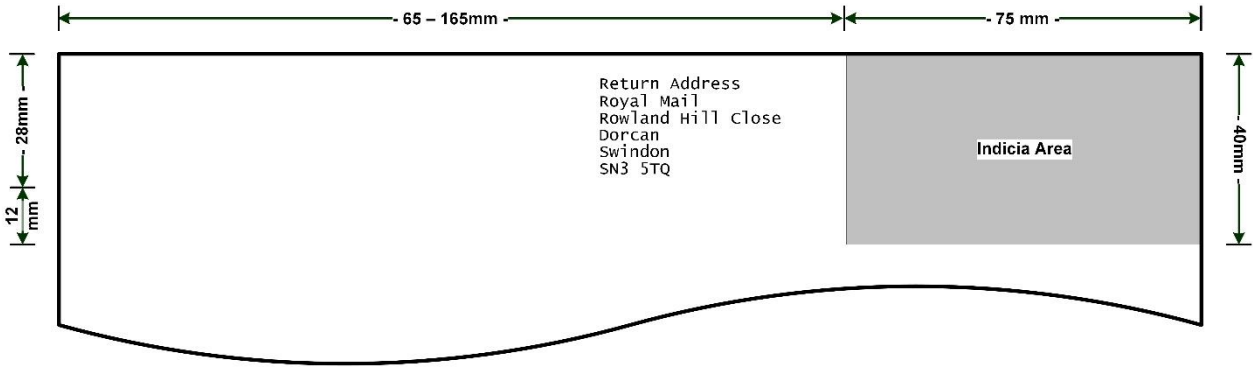

Figure 15 – Letter Return Address – Front Landscape Example B (Not to Scale)



### 2.8.3 Mailmark Letters – Mailmark Figures

Figure 16 – 4-State Mailmark Barcode Symmetry

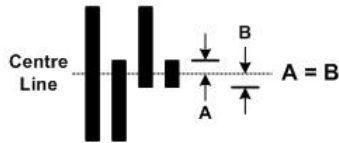

Figure 17 – 4-State Mailmark Barcode Bar Skew Y (Not to Scale)

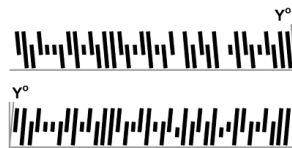

Figure 18 – 4-State Mailmark Barcode Code Skew Z (Not to Scale)



## 2.8.4 Mailmark Letters - Other Mailmark Mailer Figures

### 2.8.4.1 One Piece & Wrap Letter Mailer - Figures

Figure 19 - Standard One-Piece Letter Mailer - Spot Weld Requirements (Not to Scale)

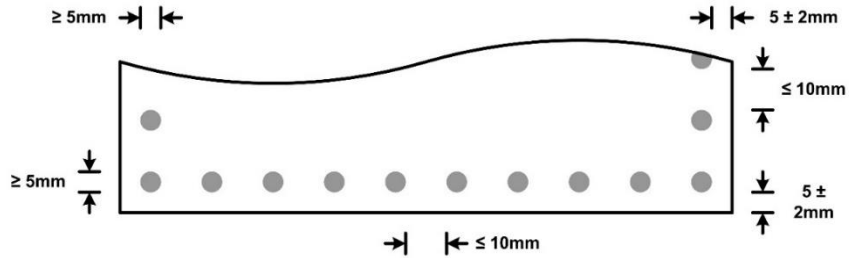

Figure 20 - Standard One-Piece Letter Mailer - Adhesive Line Requirements (Not to Scale)



Figure 21 - Feature Letter Mailer (Not to Scale)

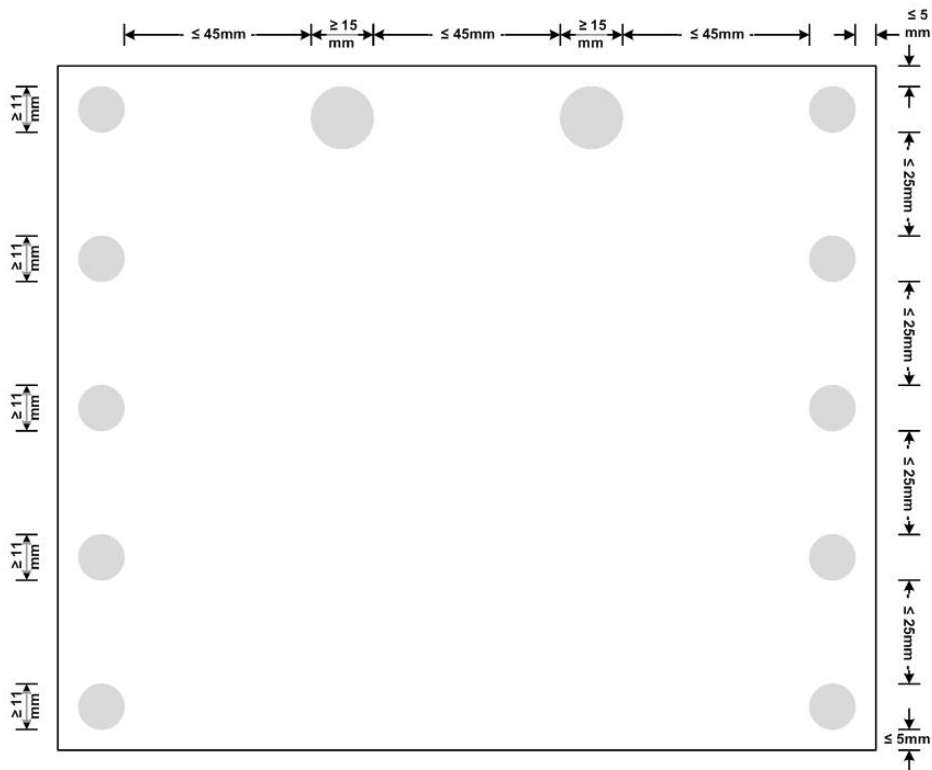

Figure 22 - Coupon One-Piece Letter Mailer - Dimensions (Not to Scale)

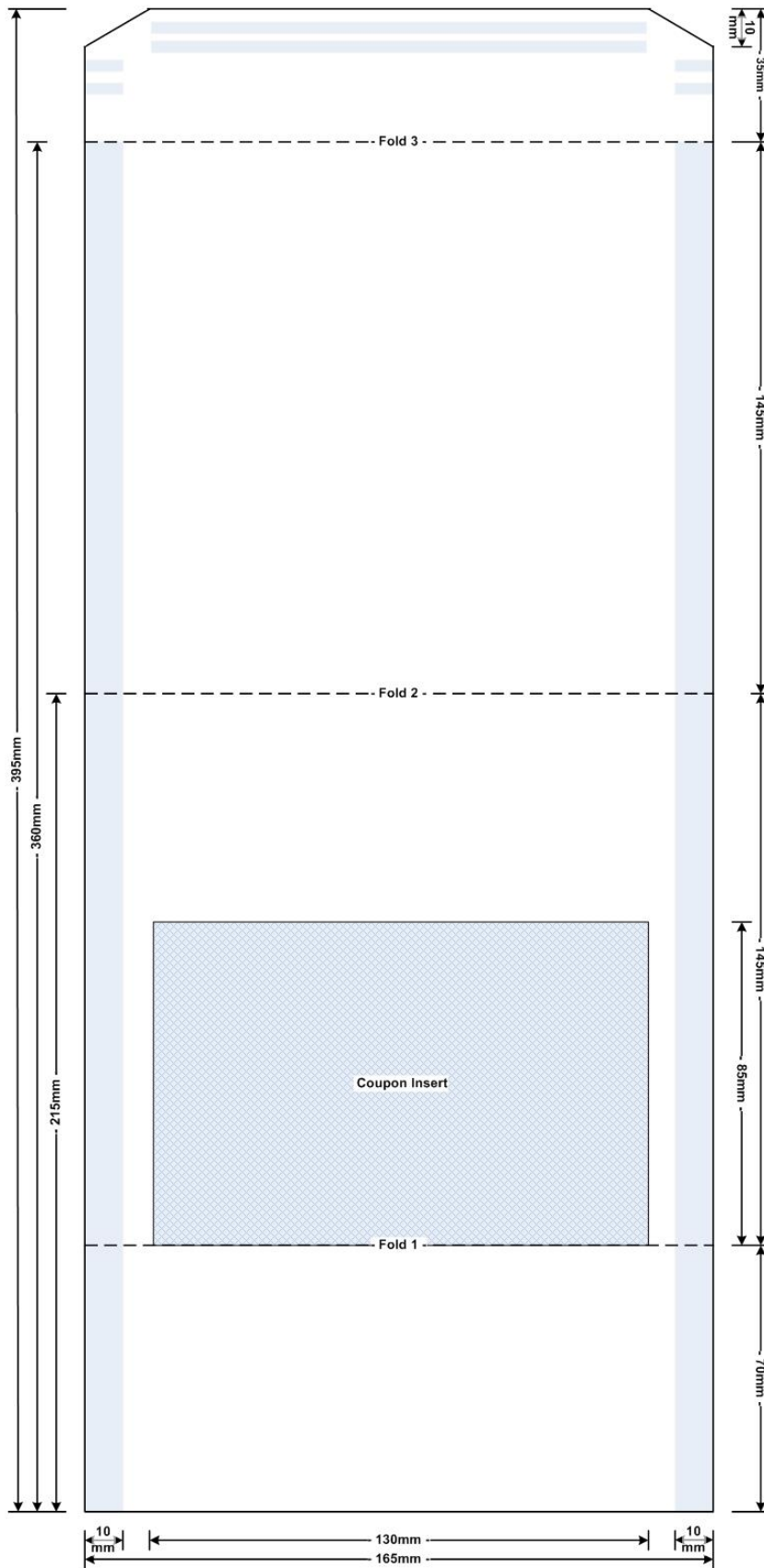

Figure 23 – Coupon One-Piece Letter Mailer – Finished Back View (Not to Scale)

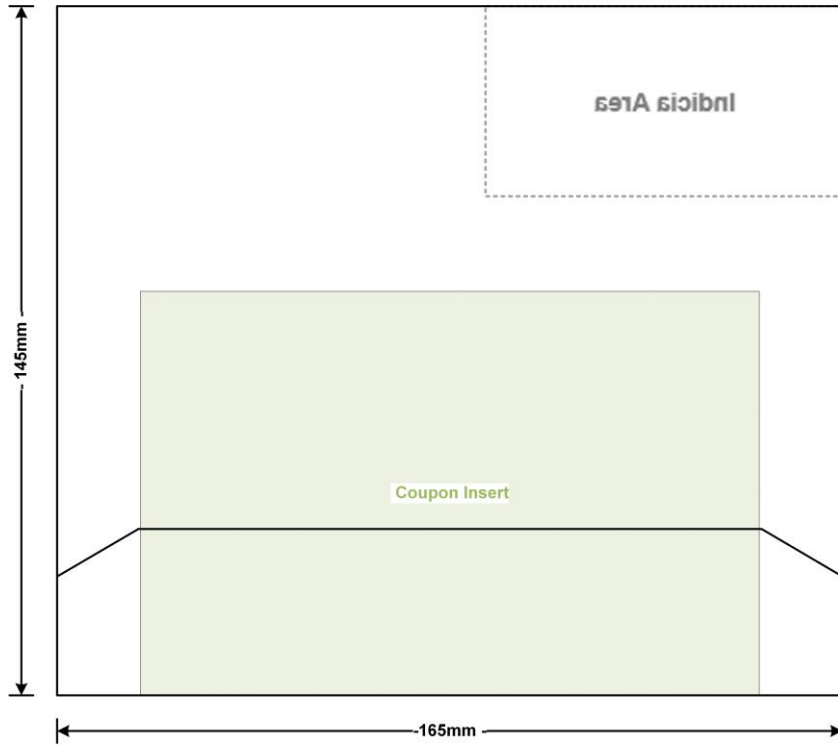

Figure 24 – Machineable Postcard - Option 1 (Not to Scale)

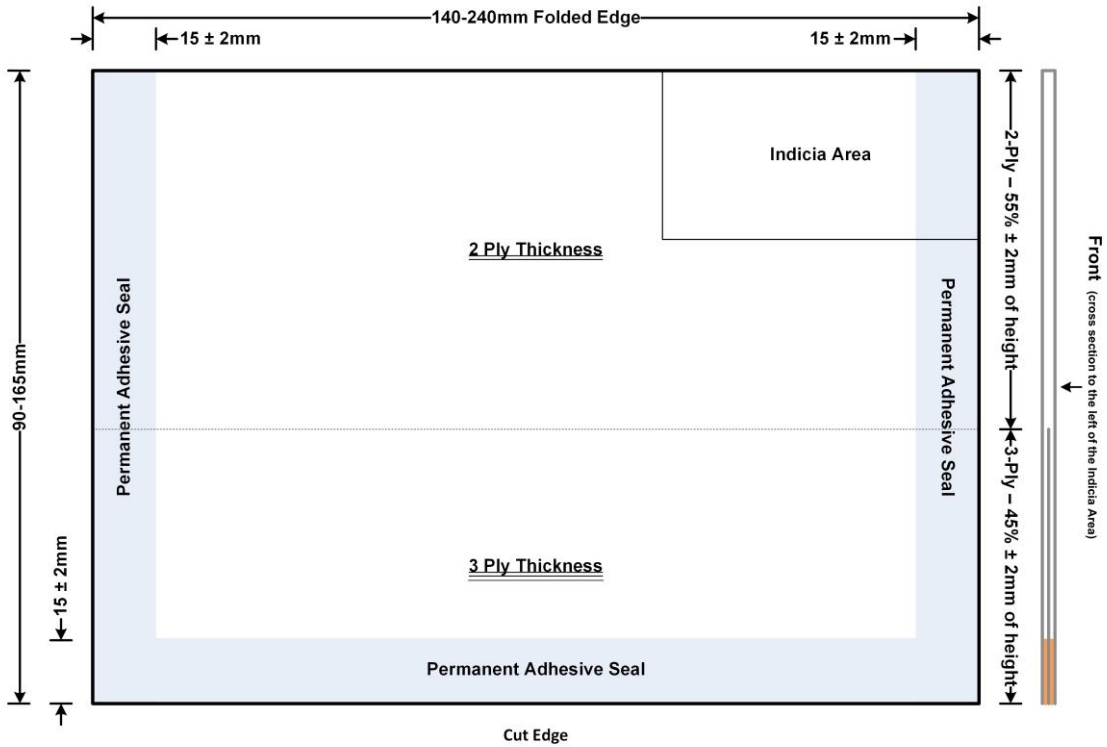
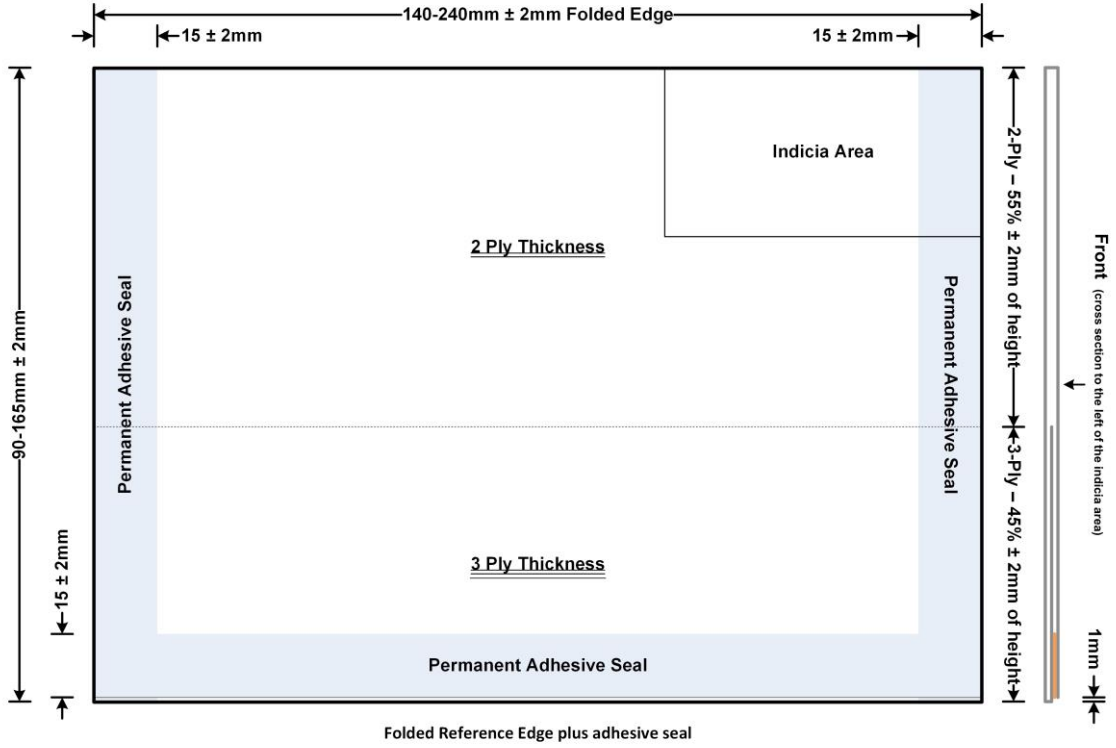

Figure 25 – Machineable Postcard - Option 2 (Not to Scale)



### 2.8.4.2 Perforated Letter Mailers - Figures

Figure 26 - Tamper Evident - Roulette Perforated Mailer - Landscape (Not to Scale)

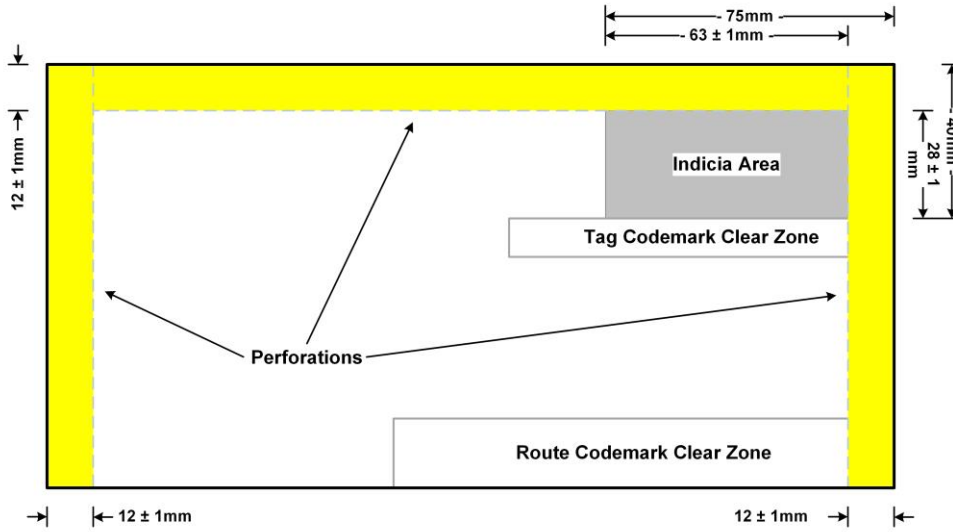

Figure 27 - Tamper Evident - Roulette Perforated Mailer - Portrait (Not to Scale)

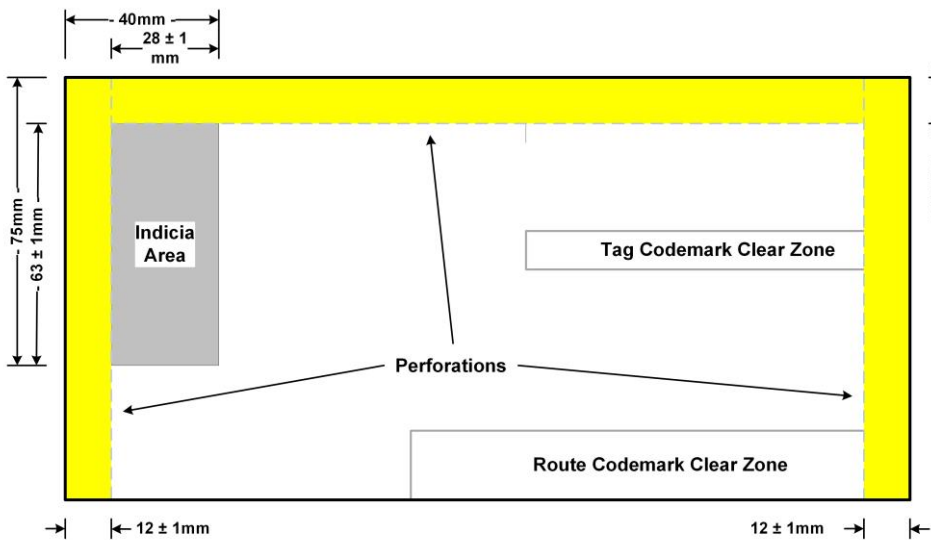

Figure 28 - Roulette Perforation Dimensions (Not to Scale)

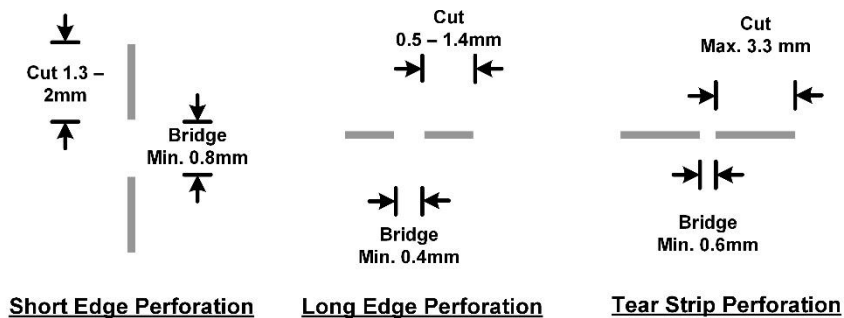

Figure 29 - Tamper Evident - Pressure Seal Perforated Mailer - Front Perforations (Not to Scale)

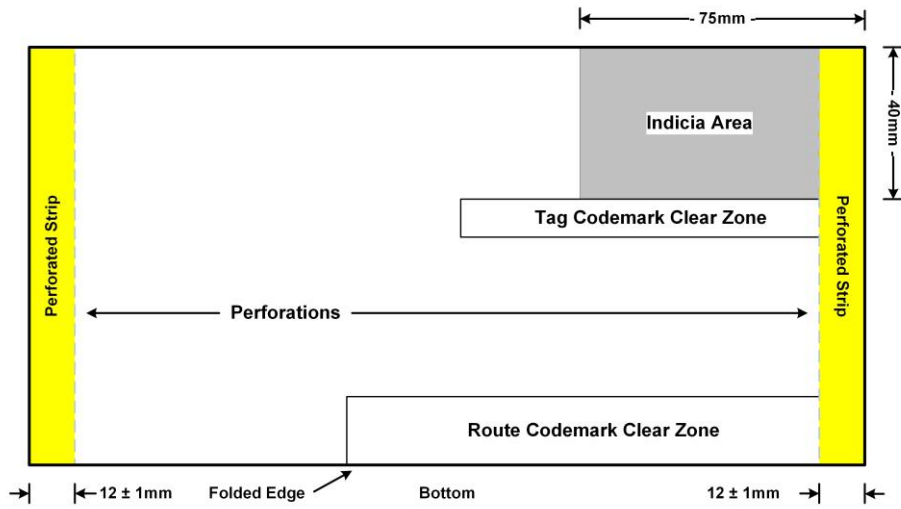

Figure 30 - Tamper Evident - Pressure Seal Perforated Mailer - Back Perforations (Not to Scale)

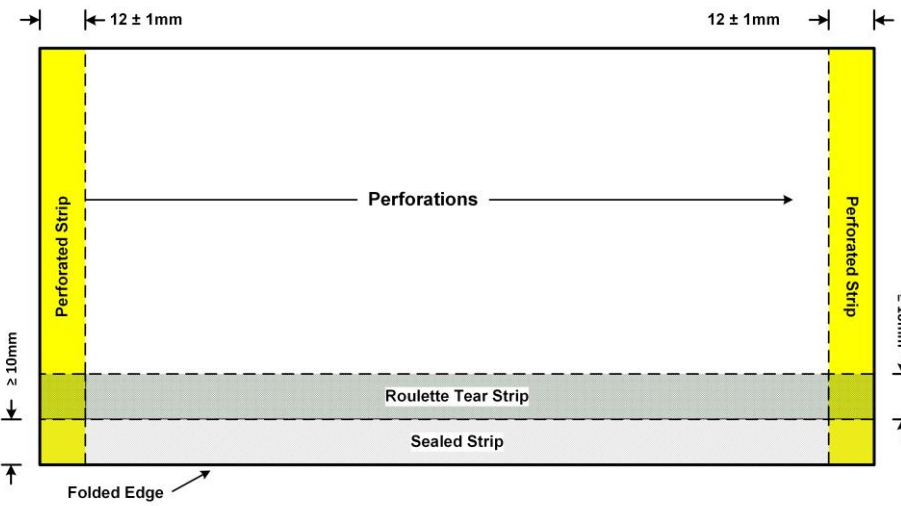

Figure 31 - Fold & Seal Mailer - Open Perforations

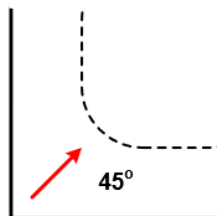

Figure 32 - Fold & Seal Mailer - Finished Dimensions (Not to Scale)

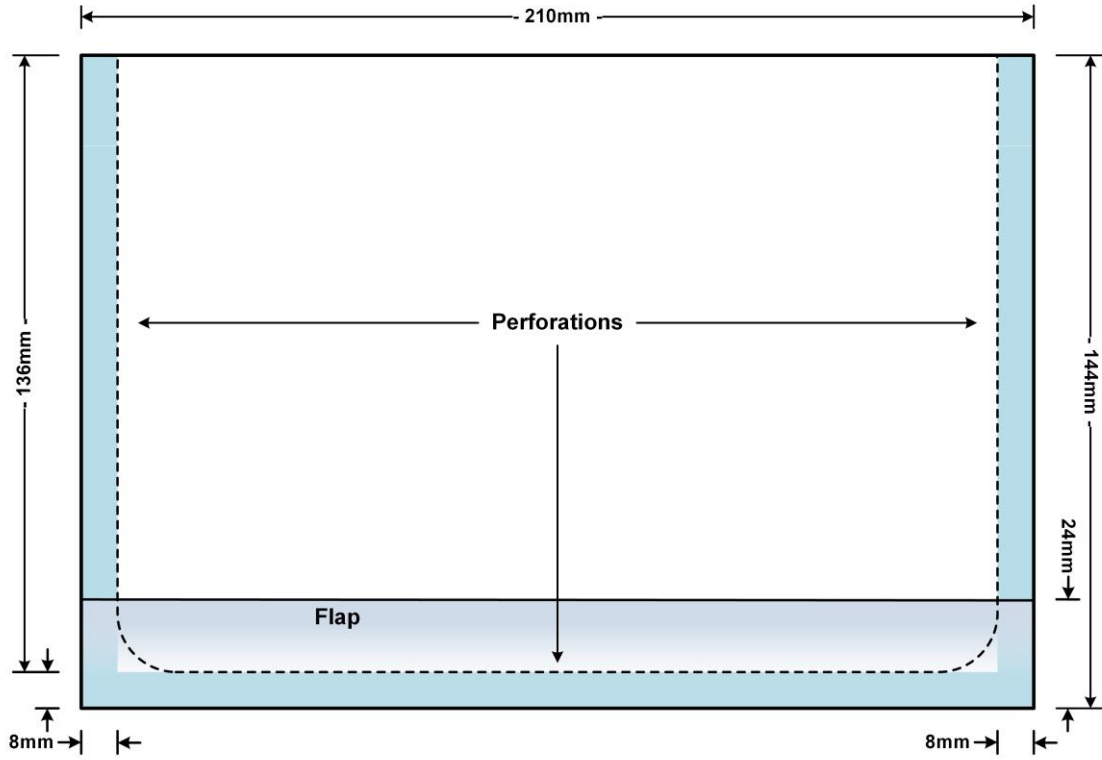

Figure 33 - Fold & Seal Mailer - Open Dimensions (Not to Scale)

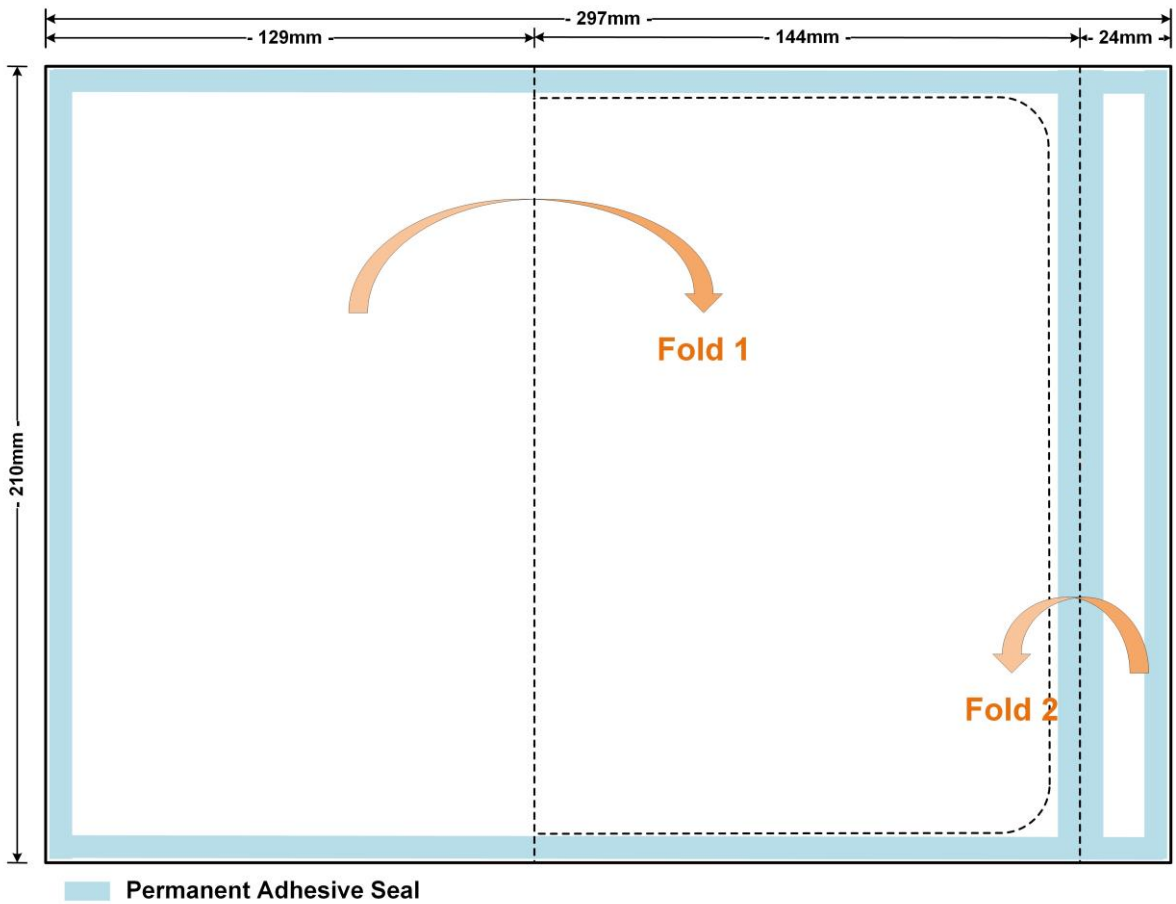
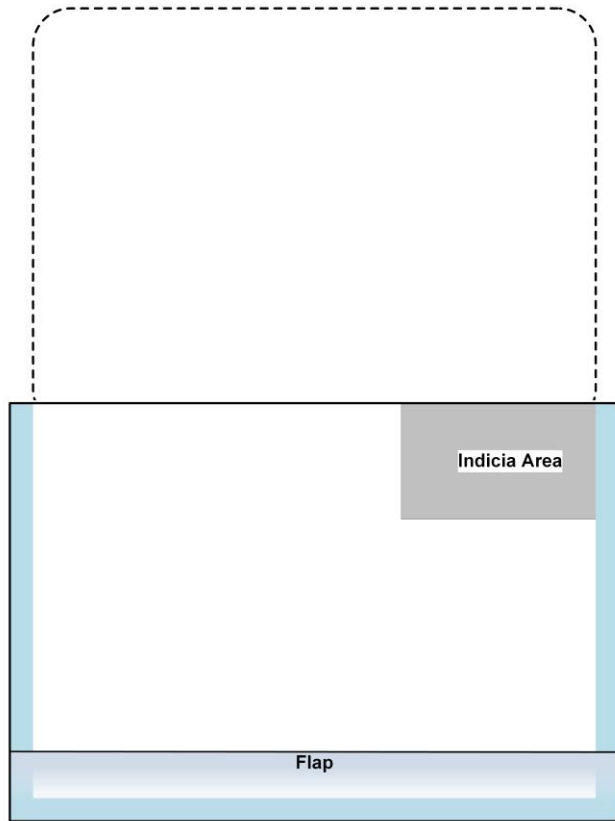
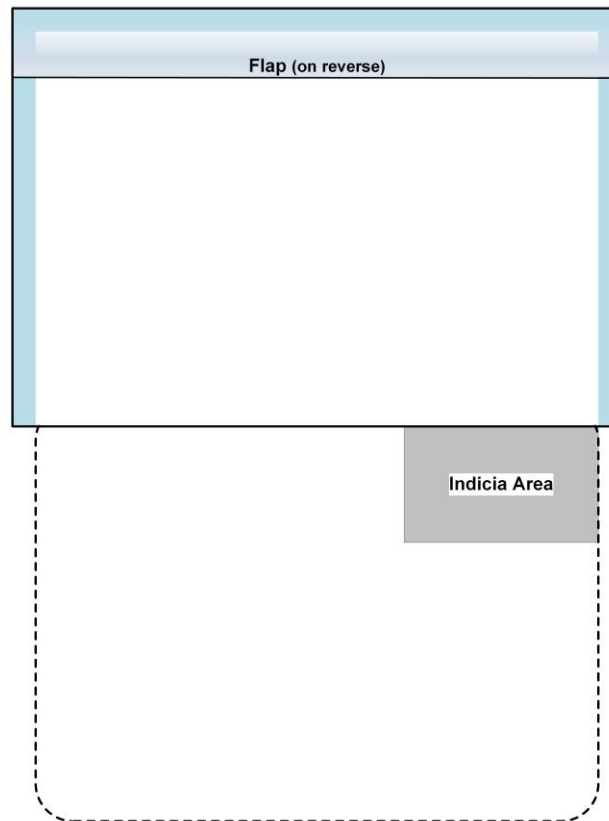

Figure 34 - Fold & Seal Mailer Design Options

Version 1 - Back Perforated opener with Bottom Front Flap



Version 2 - Front Perforated opener with Bottom Back Flap



Version 3 - Front Perforated opener with Top Back Flap

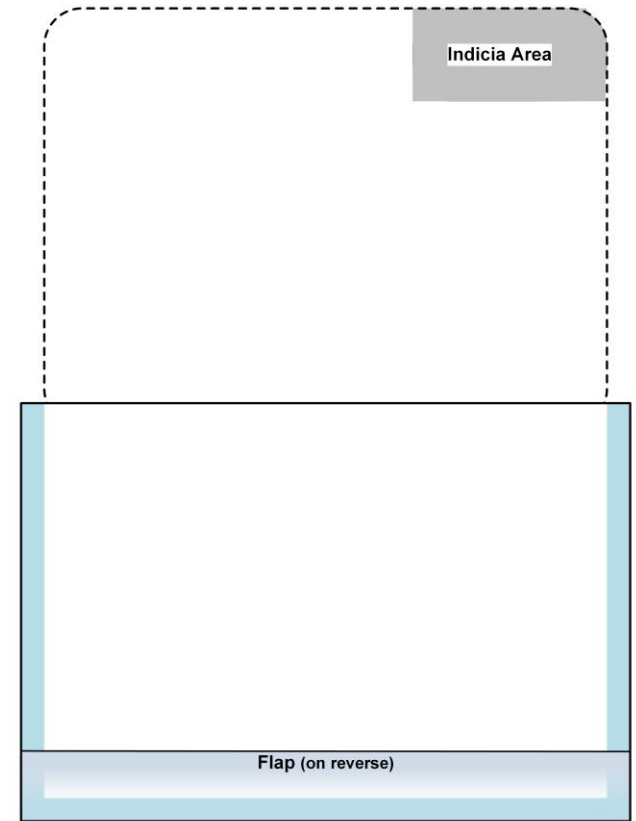

Figure 35 - Fold & Seal Mailer with Coupon - Finished Dimensions (Not to Scale)

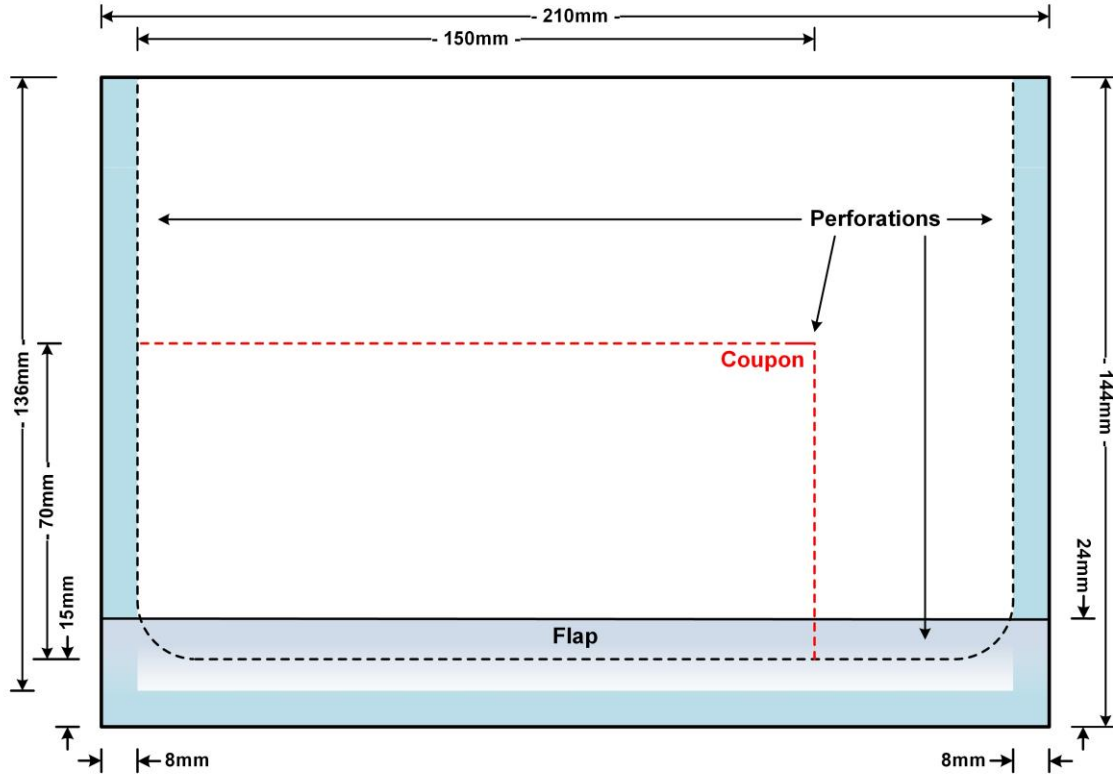

Figure 36 - Fold & Seal Mailer with Coupon - Open Dimensions (Not to Scale)

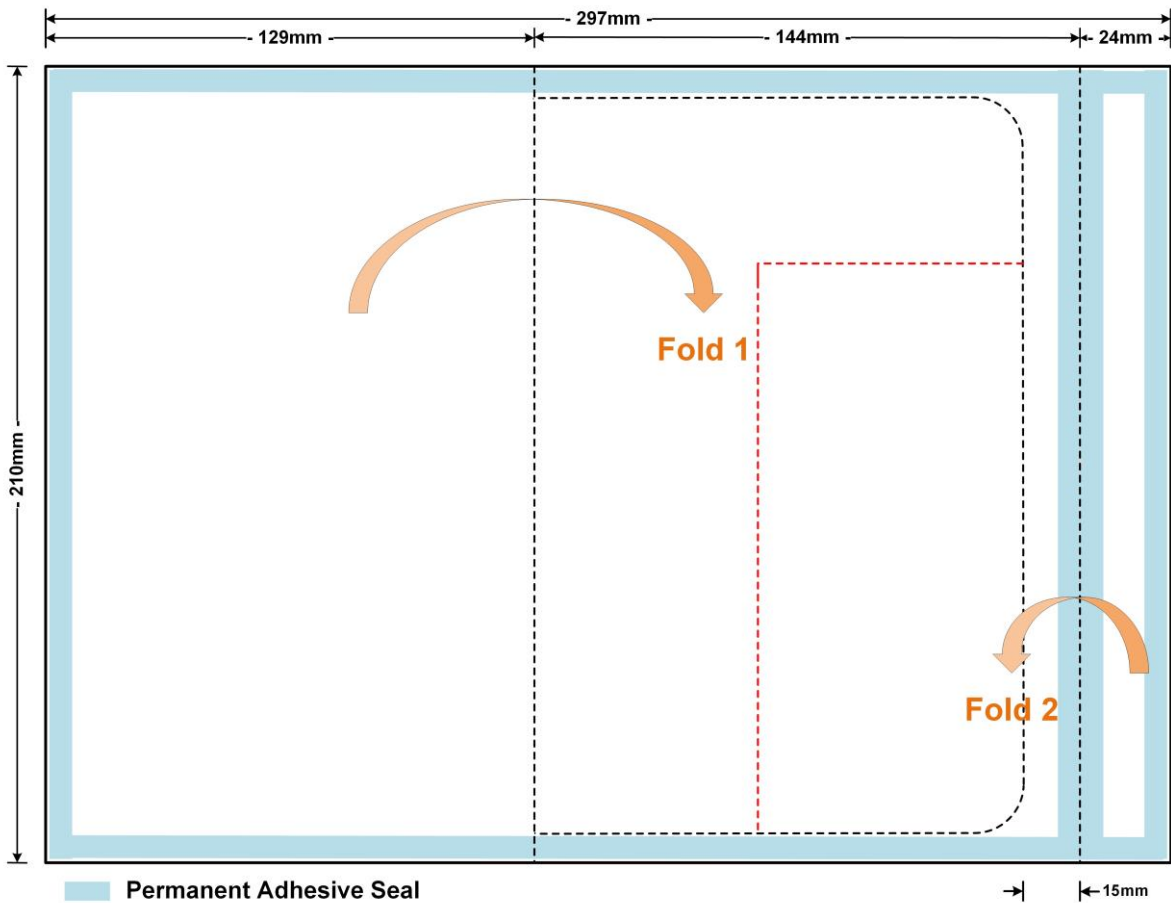
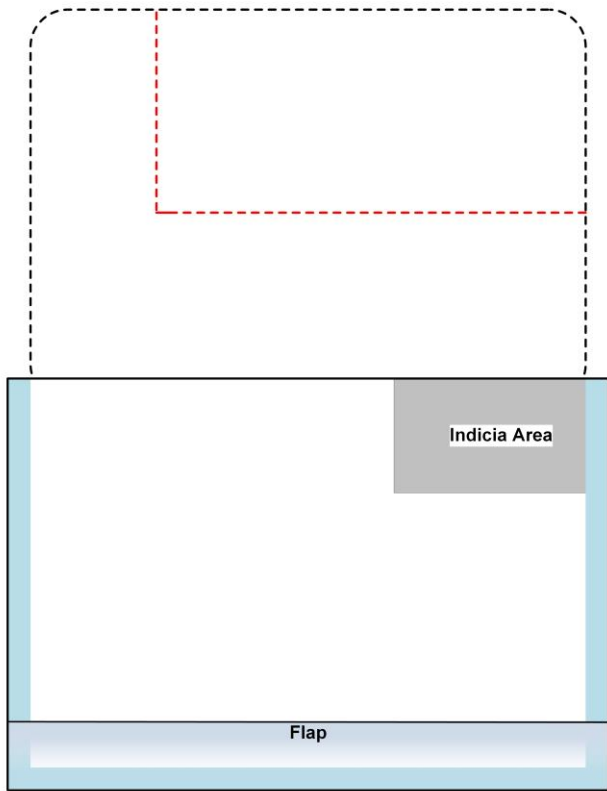

Figure 37 - Fold & Seal Mailer with Coupon Design Options

Ver 1 - Back Perforated opener with Voucher & Bottom Front Flap



Ver 2 - Front Perforated opener with Voucher & Bottom Back Flap

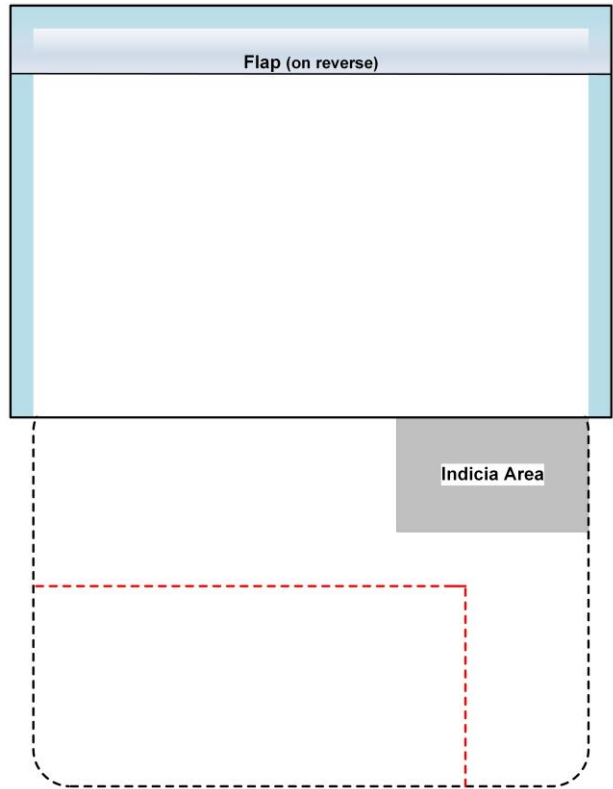

Figure 38 - Zip Tie Orientation (back view) - Landscape Mail

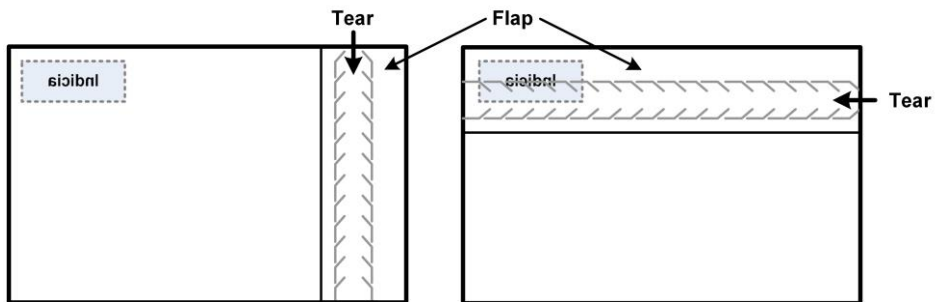

Figure 39 - Zip Tie Orientation (back view) - Portrait Mail

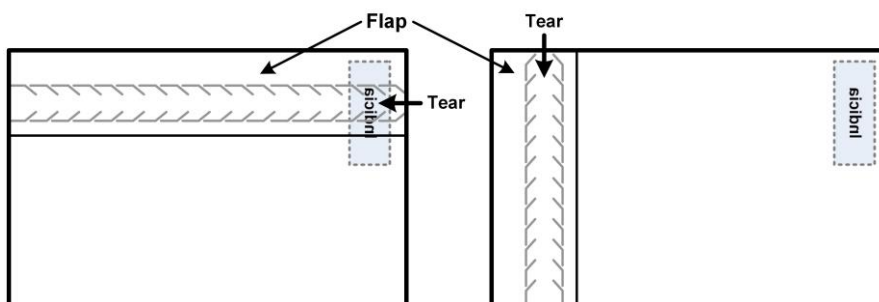

Figure 40 – Zip Tie ‘Envelope’ Flap (Not to Scale)

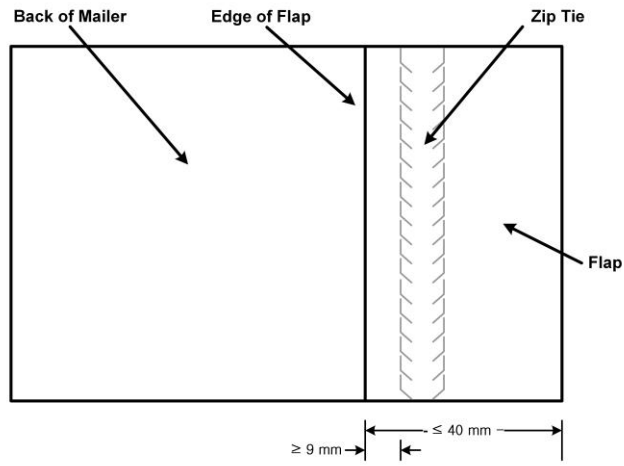
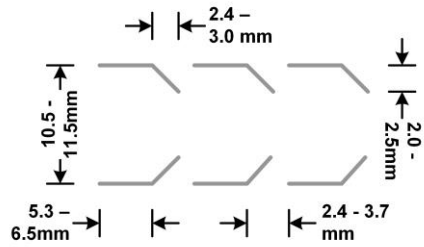

Figure 41 – Zip tie Dimensions (Not to Scale)



### 2.8.4.3 Tabbed Mailer - Figures

Figure 42 - Tabbed - DL Thin Letter (Not to Scale).

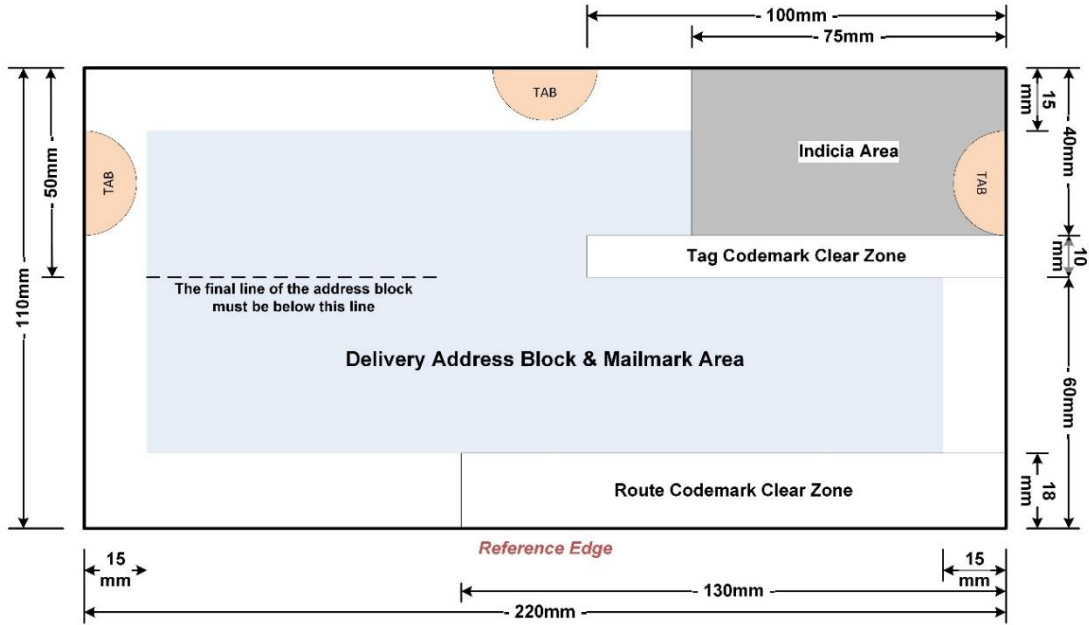

Figure 43 - Tabbed - DL Thicker / Heavier Letter (Not to Scale).

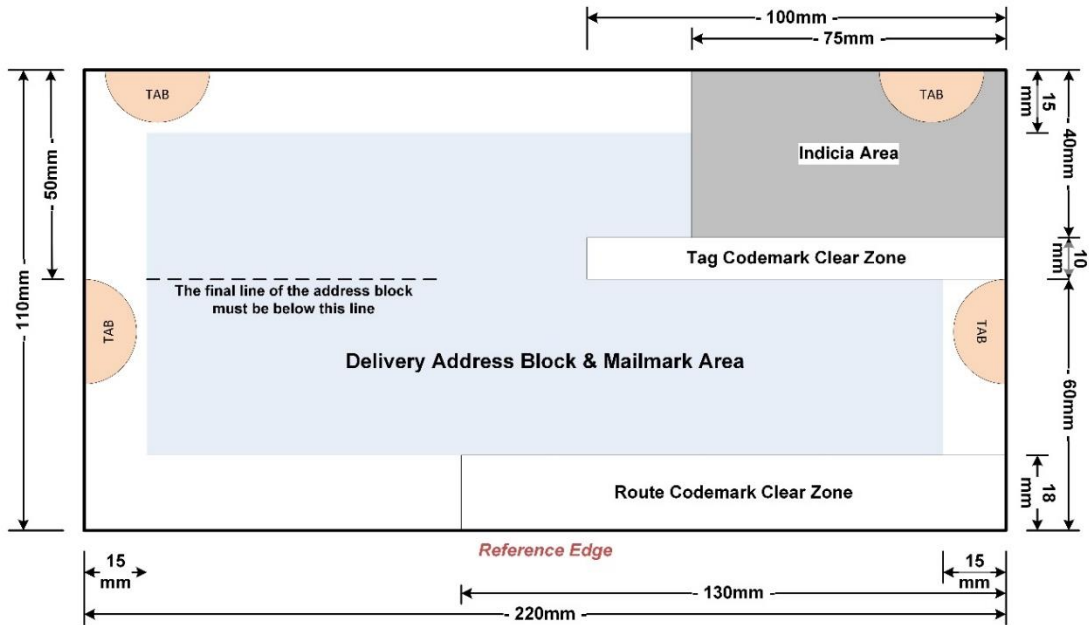

Figure 44 – Tabbed – Maximum Size Landscape Letter (Not to Scale).

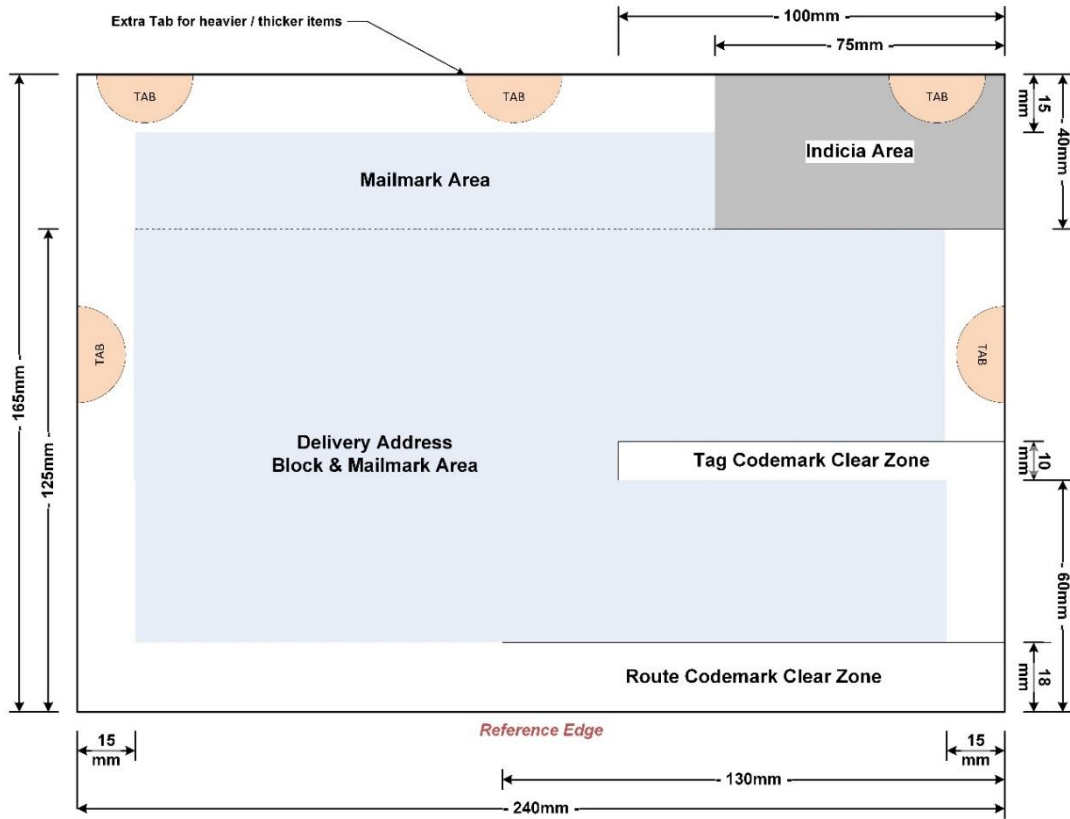
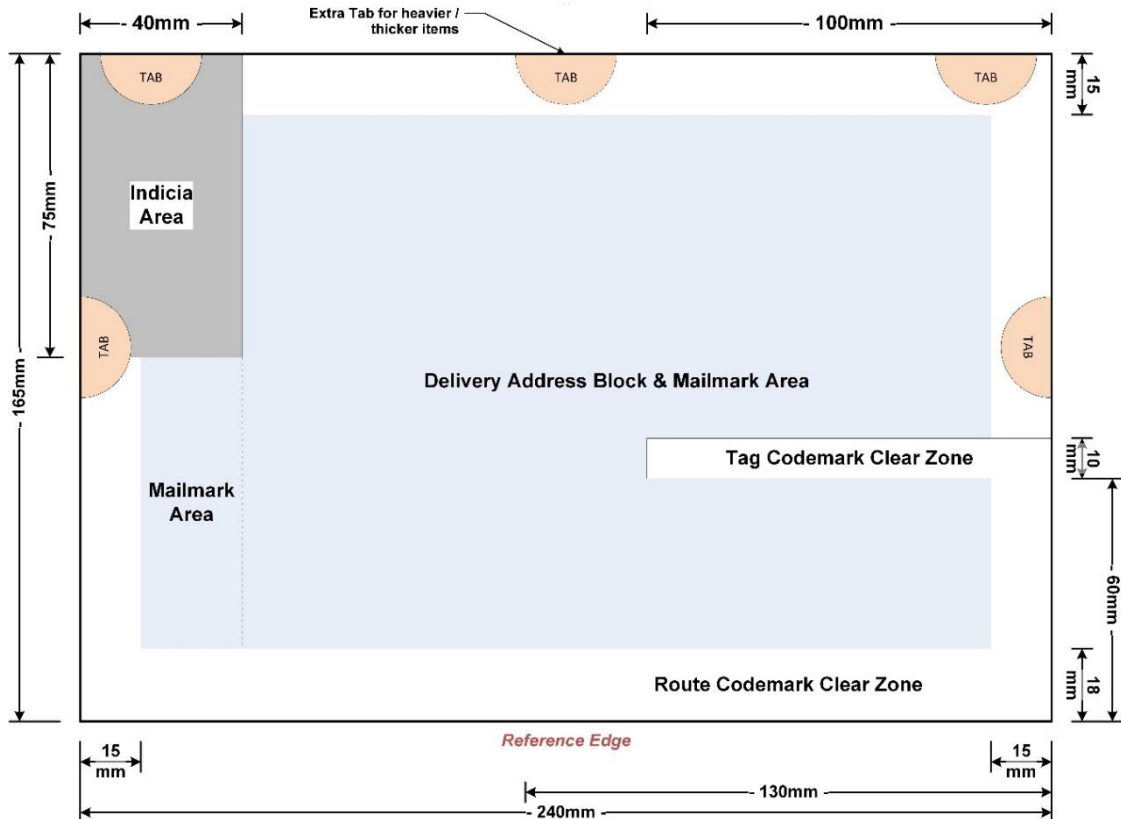

Figure 45 – Tabbed – Maximum Size Portrait (Not to Scale)



### 3. Mailmark Large Letters

#### 3.1.1 Mailmark Large Letters – Physical – Generic

These requirements apply to all Large Letters unless stated otherwise.

Category		Specification Requirement	M/R
Size, Shape & Design	Shape	Rectangular or square with straight sides and 90° corners	M
	Orientation	Landscape or portrait	M
	Size (H x L)	<u>Rectangular</u> Minimum – 95mm x 145mm, Maximum – 245mm x 345mm <u>Square</u> Minimum – 145mm x 145mm, Maximum – 245mm x 245mm	M
	Thickness	Minimum – 0.5mm, Maximum – 13mm	M
	Weight	Minimum – 10g, Maximum – 750g	M
	Aspect Ratio (rectangular items)	Subject to maximum and minimum dimensions, the length of rectangular mailpieces must be at least 1.4 times greater than the width of the Large Letter. e.g. A Large Letter of 200mm in height would have a minimum length of 280mm <sup>67</sup> .	H <sup>69</sup>
	Content / Inserts	<ul style="list-style-type: none"> <li>Inserts other than paper that are placed in an envelope must be fixed in position and attached to the largest paper insert. The inserts may include small metal objects such as keys, coins, and badges.</li> <li>Non-metallic Punch &amp; bind bindings on the short edge <sup>68</sup> are acceptable if aligned to left edge of the mailpiece. i.e. To the left for landscape items and at the top for portrait items.</li> <li>The spines of magazine inserts should be located on the reference edge <sup>70</sup>.</li> </ul>	M L <sup>69</sup> L <sup>69</sup>
	Spatial Distortion & Lateral Movement	<ul style="list-style-type: none"> <li>Where there are step changes (i.e. multiple inserts) in the thickness of the Large Letter, at least 50% of the overall thickness of the Large Letter must be uniform.</li> <li>The lateral movement of the largest paper insert should be no more than 30mm (see Figure 46).</li> </ul>	M H <sup>71</sup>
	Flexibility	The acceptable rigidity or stiffness for a Large Letter must be at least 8N.mm. This is determined using the test below (see Figure 47) :- <ul style="list-style-type: none"> <li>A single Large Letter is placed on a flat surface with the shortest edge of the Large Letter overhanging a straight edge of a flat surface by a horizontal distance of 100mm<sup>72</sup>.</li> <li>The leading edge of the Large Letter is then released and allowed to bend down under its own weight. If the leading edge drops to 40mm or more, then the stiffness is less than 8N/mm and the Large Letter is unmachineable.</li> </ul>	M
	Separation	<ul style="list-style-type: none"> <li>Large Letters must be capable of separating by sliding one from another under the force of gravity, when placed on a slope of 65 degrees to the horizontal (see Figure 50).</li> </ul>	M
Do Not Redirect	Not permitted for Large Letters		
Logos & Advertising	<ul style="list-style-type: none"> <li>Any logo or advertising slogan printed on the Large Letter should not look like a payment indicia or an address or include a geographical location, country or a Royal Mail bag or bundle label.</li> </ul>	L <sup>73</sup>	

<sup>67</sup> Height @ 200mm x 1.4 = 280mm.

<sup>68</sup> Long edge bindings have not yet been evaluated.

<sup>69</sup> This enables effective presentation to the machine and subsequent processing.

<sup>70</sup> The reference edge is the edge beneath the address for landscape rectangular and square Large Letters and the long edge to the left of the address for portrait Large Letters. The reference edge enables the Large Letter to be processed through the machines efficiently.

<sup>71</sup> Where the Letter Large thickness is variable and lateral movement is high, there is an increased risk of the Large Letter content being separated from the envelope or wrap and consequent machine jams.

<sup>72</sup> Where there is a difference in the weight at the short edges, the heaviest edge must overhang.

<sup>73</sup> To reduce any potential for address reading errors,

Category	Specification Requirement	M/R
	<ul style="list-style-type: none"> <li>Slogans where the company name contains the words 'Return', 'Address' and 'Undelivered' should be avoided.</li> </ul>	L <sup>73</sup>

### 3.1.1.1 Mailmark Large Letters - Labels

Labels may be used for address and/or indicia content and/or Mailmark code content.

Requirements for the location of the indicia, delivery address block, return address block, and Mailmark codes remain as specified in sections 3.1.1 - 3.4.

Requirements for Mailmark code quality, clear zones, skew, opacity etc. remain unchanged.

Category	Specification Requirement	M/R	
Physical	Peel adhesion	The peel adhesion strength of the label must be sufficient to ensure that fibre tear is exhibited on separation	M
	Shape	Labels should be rectangular or square and have radiused corners	H <sup>74</sup>
	Opacity	The paper used should be at least 85 % opaque (BS ISO 2471 - Paper and board. Determination of opacity)	H <sup>75</sup>

### 3.1.2 Mailmark Large Letters - Physical - Paper Envelopes

Category	Specification Requirement	M/R	
Paper Envelope Construction	Material	<ul style="list-style-type: none"> <li>Envelopes must be made from <b>paper only</b> and have NO open apertures.</li> </ul>	M
		<ul style="list-style-type: none"> <li>Perforations (including Zip Tie perforations) must not be used on Large Letters.</li> </ul>	M
	Flaps	The opening flap may fold to either the back or the front of the Large Letter.	L <sup>76</sup>
	Sealing	<ul style="list-style-type: none"> <li>Adhesives used must be dry and must not leak onto the open surface of the Large Letter.</li> </ul>	M
		<ul style="list-style-type: none"> <li>Large Letters must not be stuck or caught together.</li> </ul>	M
		<ul style="list-style-type: none"> <li>Envelopes must be securely sealed on the front, back, and all edges.</li> <li>The flap should be sealed to within a minimum of 35mm from the fold of the envelope flap, and 25mm from the envelope sides (see Figure 48).</li> </ul>	H <sup>77</sup> L <sup>78</sup>
	Paper Weight	Minimum 70gsm for envelopes & minimum 200gsm for postcards	H <sup>79</sup>
	Opacity	The paper used should be at least 85 % opaque (BS ISO 2471 - Paper and board. Determination of opacity).	H <sup>80</sup>
Absorbency	The paper used should have an absorbency of 15-35 gsm of water in 1 minute (BS EN 20535 - Paper and board. Determination of water absorptiveness).	H <sup>81</sup>	
Porosity	The paper used should have a porosity value of less than 700 ml per minute (BS 6538-2 - Air permeance of paper and board).	L <sup>82</sup>	

<sup>74</sup> This facilitates address reading and optimises label adhesion.

<sup>75</sup> This facilitates Mailmark, address, and Indicia reading.

<sup>76</sup> There is no preference here.

<sup>77</sup> This ensures that the seals are strong enough to remain intact during the rigours of mechanical and manual handling.

<sup>78</sup> This may result in the unsealed portion of the flap being torn during processing.

<sup>79</sup> This ensures that the Large Letter is strong enough to withstand the rigours of mechanical and manual handling.

<sup>80</sup> This facilitates Mailmark, address, and Indicia reading.

<sup>81</sup> This facilitates the application of codes and artwork to the Large Letter (i.e. the ink soaks in and does not rub off).

<sup>82</sup> This facilitates the single item sorting when mail is placed on the machine (i.e. fewer double fed Large Letters and missorts).

Category		Specification Requirement	M/R
Window	Fixing	<ul style="list-style-type: none"> <li>Envelopes with apertures must have a window film covering the aperture, and the film must be securely sealed to the inside of the envelope on all sides of the aperture.</li> <li>The Delivery Address block should be visible through the window.</li> </ul>	M H <sup>83</sup>
	Fixing Cont.	<ul style="list-style-type: none"> <li>The window film should be flat and fixed evenly across the surface area it is in contact with.</li> <li>The window film should be robust enough not to become creased, crumpled or otherwise deformed.</li> </ul>	H <sup>84</sup> H <sup>84</sup>
Window Cont.	Number	There should be no more than 1 window on the front of the Large Letter.	L <sup>85</sup>
	Size	The window must take up no more than 25% of the surface area.	M
	Shape	Windows should be rectangular (with rounded corners).	L <sup>79</sup>
	Position	Windows must be located at least 40mm from the top edge and at least 15mm from the left, right and bottom edges (see Figure 57 and Figure 58).	M
	Gloss	The maximum gloss value for the window should not exceed 150 when measured at 60°, in accordance with American Standard Test Method (ASTM) 2457.	H <sup>83</sup>
	Haze	The maximum haze value for the window should not exceed 75% in accordance with (ASTM D1003-00 Procedure A (Hazemeter)).	H <sup>83</sup>

### 3.1.3 Mailmark Large Letters – Physical – Paper Wrap

These requirements apply in addition to the generic Large Letter requirements.

Category		Specification Requirement	M/R
Paper Wrap Construction & Design	Material	<ul style="list-style-type: none"> <li>Envelopes must be made from <b>paper only</b> and have NO open apertures.</li> </ul>	M
		<ul style="list-style-type: none"> <li>The Wrap must be sufficiently robust to tolerate processing and manual handling without tearing or splitting at the seals. Perforations (including Zip Tie perforations) must not be used on Large Letters.</li> </ul>	M
	Paper Weight	Minimum 90 gsm	H <sup>86</sup>
	Lateral Movement	<ul style="list-style-type: none"> <li>The lateral movement of the largest paper insert must be no more than 20mm.</li> </ul>	M
	Folds & Edges <sup>87</sup>	<ul style="list-style-type: none"> <li>The long edges of the finished mailpiece must be folds.</li> </ul>	M
		<ul style="list-style-type: none"> <li>The short edges may be folded or sealed, and flap must be sealed.</li> </ul>	M
	Reference Edge	<ul style="list-style-type: none"> <li>The reference edge must be a folded edge on the mailpiece.</li> </ul>	M
<ul style="list-style-type: none"> <li>For landscape the folded reference edge is the edge beneath the address.</li> </ul>		M	
<ul style="list-style-type: none"> <li>For portrait items the reference edge is the longest left edge.</li> </ul>		M	
<ul style="list-style-type: none"> <li>For square mailers, the reference edge is the edge beneath the address.</li> </ul>		M	
	<ul style="list-style-type: none"> <li>If the flap/long seal is located on the front of the Large Letter, the Delivery Address Block and the Mailmark Code must not be positioned over the flap/long seal.</li> </ul>	M	

<sup>83</sup> This facilitates Mailmark and address reading.

<sup>84</sup> This ensures that the Large Letter is strong enough to withstand the rigours of mechanical and manual handling and facilitates Mailmark and address reading.

<sup>85</sup> This facilitates Mailmark and address reading.

<sup>86</sup> This ensures that the Large Letter is strong enough to withstand the rigours of mechanical and manual handling.

<sup>87</sup> Cross-strapping of bundles should be avoided. Short edge bundling is acceptable.

Category		Specification Requirement	M/R
Paper Wrap Cont.	Flap / Long Seal	<ul style="list-style-type: none"> <li>The flap/long seal should run parallel to the reference edge and open from the bottom.</li> <li>The free edge of the flap/long seal should be less than 30mm deep.</li> <li>The preferred location for the flap/long seal is on the back of the Large Letter.</li> <li>The maximum height for a flap/long seal depends on the mailpiece size but should be least 40mm from the bottom of the mailpiece.</li> </ul>	<p>H <sup>79</sup></p> <p>H <sup>79</sup></p> <p>L <sup>88</sup></p> <p>L <sup>88</sup></p>
	Adhesive Application	<ul style="list-style-type: none"> <li>Where there are gaps in the continuous seal adhesive application, they should be ideally located at top of the mailer and may be on left and / or the right side and should be no more than 5-10mm long.</li> </ul>	H <sup>89</sup>
	Sealing	<ul style="list-style-type: none"> <li>The wrap must be securely sealed on the flap/long seal and front, back, and all edges.</li> <li>The flap/long seal must be glued with a continuous seal.</li> <li>The Flap / long seal must be a minimum 2.5mm wide sealed to within 3mm-5mm of the edge.</li> <li>The side seals must be a minimum 4mm wide and to the edge.</li> <li>Adhesives used must be dry and fully cured and must not leak onto the open surface of the Large Letter.</li> <li>Large Letters must not be stuck or caught together.</li> <li>The adhesive must not run out onto the outside of the Large Letter or produce protruding mounds on the Large Letter.</li> <li>The adhesive must not be brittle or easily broken.</li> <li>All unfolded sides must be glued with a continuous seal or with a line of 'dashes' of adhesive that must be at least 10mm long and no more than 5mm apart.</li> <li>The adhesive should be no more than 80 microns thick</li> </ul>	M
			M
			M
			M
			M
M			
Peel Adhesion	<ul style="list-style-type: none"> <li>The peel adhesion strength of the adhesive that is used for the side seals has yet to be determined. Paper fibres must be seen to tear if the seal is peeled apart.</li> <li>The adhesive used for the flap/long seal may be semi-permanent,</li> </ul>	<p>M</p> <p>H <sup>79</sup></p>	
Opacity	The paper used should be at least 85 % opaque (BS ISO 2471 - Paper and board. Determination of opacity).	H <sup>91</sup>	
Porosity	The paper used should have a porosity value of less than 700 ml per minute (BS 6538-2 - Air permeance of paper and board).	L <sup>92</sup>	
Window Location	Where a window is required on the same side of the mailer as the Flap / Long Seal, it must be located at least 25mm away from the Flap / Long Seal.	M	
	The preferred location for any window that is required is on the opposite side to the Flap / Long Seal.	H <sup>93</sup>	

<sup>88</sup> This ensures that the Large Letter is strong enough to withstand the rigours of mechanical handling.

<sup>89</sup> This aims to maximise the strength of the side seals, whilst preventing bursting and potential machine input issues.

<sup>90</sup> Adhesive welds greater than this thickness may cause mechanical handling issues.

<sup>91</sup> This facilitates Mailmark, address, and Indicia reading.

<sup>92</sup> This facilitates the single item sorting when mail is placed on the machine (i.e. fewer double fed Large Letters and missorts).

<sup>93</sup> This avoids any weaknesses that may result from the proximity of the window to the Flap / Long Seal.

### 3.1.4 Mailmark Large Letters – Physical – Polymer Wrap

Category		Specification Requirement	M/R
Polymer Wrap Construction & Design	Material	<ul style="list-style-type: none"> <li>Polymer Large Letters must be made from a polymer film <sup>94</sup>. e.g. polyethylene.</li> </ul>	M
		<ul style="list-style-type: none"> <li>The film must be intact, undamaged and must not be punctured, split, or torn <sup>95</sup>.</li> </ul>	M
		<ul style="list-style-type: none"> <li>The film must be sufficiently robust to tolerate manual handling without tearing or splitting at the seals.</li> </ul>	M
		<ul style="list-style-type: none"> <li>The single layer film must be greater than 15 µm (15 microns) thick when measured at any point on the Large Letter.</li> </ul>	M
		<ul style="list-style-type: none"> <li>Where the Delivery Address is to be read through the film, the gloss value should not exceed 150 (American standards of testing and materials (ASTM) 2457 Measured at 60°).</li> </ul>	H <sup>91</sup>
	<ul style="list-style-type: none"> <li>Where the Delivery Address is to be read through the film, the haze value should not exceed 75 % (ASTM D1003-00 Procedure A (Hazemeter)).</li> </ul>	H <sup>91</sup>	
Design	Any text, barcode, or graphics that are printed on the wrap should adhere to the film and should not break up or wear during processing.	M	
Sealing	<ul style="list-style-type: none"> <li>The wrap must be securely sealed.</li> </ul> <p>The requirements for the Longitudinal Seal and its associated flap are as follows (see Figure 53) :-</p> <ul style="list-style-type: none"> <li>The seal for the Polymer wrap must run along the length of the Large Letter.</li> <li>The seal must be secured along the whole length of the seal and at each end.</li> <li>The free edge of the seal must be less than 30mm deep.</li> <li>When located on the front of the Large Letter, the seal must not be over the Delivery Address Block or the Mailmark Code.</li> <li>The preferred location for the seal is on the back of the Large Letter.</li> </ul>	M	
		M	
		M	
		H <sup>96</sup>	
		M	
	L <sup>96</sup>		

### 3.1.5 Mailmark Large Letters – Physical – Polymer Envelope

Category		Specification Requirement	M/R
Polymer Envelope Construction & Design	Material	<ul style="list-style-type: none"> <li>Polymer Large Letters must be made from a polymer film. e.g. polyethylene.</li> </ul>	M
		<ul style="list-style-type: none"> <li>The film must be intact, undamaged and must not be punctured, split or torn <sup>95</sup>.</li> </ul>	H <sup>96</sup>
		<ul style="list-style-type: none"> <li>The film must be sufficiently robust to tolerate manual handling without tearing or splitting at the seals.</li> </ul>	M
		<ul style="list-style-type: none"> <li>The film must be greater than 15 µm (15 microns) thick when measured at any point on the Large Letter.</li> </ul>	M
	Sealing	<ul style="list-style-type: none"> <li>The polymer envelope must be fully sealed.</li> <li>Any adhesive sealed edges other than the opening flap must be sealed to the edge of the Large Letter.</li> <li>The adhesive must not run out onto the outside of the mail item or produce protruding mounds on the Large Letter.</li> <li>The adhesive must be fully cured prior to presentation of the mailing to Royal Mail.</li> <li>The adhesive must be stronger than the polymer.</li> <li>The opening flap should be sealed to within 25mm of the envelope at the top and sides (see Figure 49).</li> </ul>	M
			M
	H <sup>79</sup>		

<sup>94</sup> Starch based wraps (such as potato and maize starch) are untested. If they are used, they must the same standards that are required for synthetic polymers. Haze, opacity, and the strength of the polymer are particularly important.

<sup>95</sup> The only exception being polymers that are perforated for child safety purposes.

<sup>96</sup> This ensures that the Large Letter is strong enough to withstand the rigours of mechanical handling.

### 3.1.6 Mailmark Large Letters – Physical – Unwrapped (Open) Mail

The requirements in this section are provided for unwrapped mail that is not enclosed or sealed. Open sides may be tabbed if required.

Category		Specification Requirement	M/R
Unwrapped (Open) Mail Design	General	Standard physical requirements for paper Large Letters apply (see section 3.1.1), with the addition of the following specific requirements.	M
	Specific Requirements	<ul style="list-style-type: none"> <li>The spine must always be on a long edge, and this must be the reference edge <sup>97</sup></li> </ul>	M
		<ul style="list-style-type: none"> <li>The spine must be Perfect Bound, or saddle stitched. (Punch &amp; bind bindings are not permitted).</li> </ul>	M
		<ul style="list-style-type: none"> <li>Staples that are used to bind the booklet must be fully pushed through the outer cover and bent flat on the inside.</li> </ul>	M
<ul style="list-style-type: none"> <li>All pages must be secured to the binding.</li> </ul>		M	
<ul style="list-style-type: none"> <li>Loose inserts are not permitted.</li> </ul>		M	
<ul style="list-style-type: none"> <li>Covermounts / Inserts must not be attached to the mail. e.g. pens or product samples.</li> </ul>		M	
<ul style="list-style-type: none"> <li>The cover of the mail must each have a paper weight of at least 100 gsm.</li> </ul>		M	
<ul style="list-style-type: none"> <li>The pages of the booklet must have a paper weight of at least 50 gsm.</li> </ul>	M		
Gatefold Magazine Requirements <sup>98</sup>	<ul style="list-style-type: none"> <li>All pages (including the cover) must be of equal size (except any gatefold element of a cover).</li> </ul>	M	
	<ul style="list-style-type: none"> <li>Minimum magazine dimensions - Height 205mm x Length 280mm x 4mm thick</li> </ul>	M	
	<ul style="list-style-type: none"> <li>The cover must each have a paper weight of at least 115 gsm.</li> </ul>	M	
	<ul style="list-style-type: none"> <li>The cover must be no more than 2-5mm shorter than the content pages (See Figure 51).</li> </ul>	M	
	<ul style="list-style-type: none"> <li>The gate page must be no more than 5mm short of the spine (See Figure 51).</li> </ul>	M	

### 3.2 Mailmark Large Letters – Indicia

Indicia requirements are the same as those for Letters with the exception of the location, with the PPI & Digital Indicia being available.

Category		Specification Requirement	M/R
	Location	The Indicia must be located on the front of the Large Letter, above and to the right of the Delivery Address and in the top right corner of the Large Letter in the Indicia area.	M

<sup>97</sup> The reference edge is the edge beneath the address for landscape rectangular and square Large Letters and the long edge to the left of the address for portrait Large Letters. The reference edge enables the Large Letter to be processed through the machines efficiently.

<sup>98</sup> Single or double gatefolds are permitted.

### 3.3 Mailmark Large Letters – Addressing

Addressing requirements are the same as those for Letters, except for the Delivery Address and return address locations as detailed below.

Category		Specification Requirement	M/R
Delivery Address Location	General	The Delivery Address must not be printed in the border area (see Figure 57 and Figure 58):	
		<ul style="list-style-type: none"> <li>Landscape - 15mm to the top, left, right, and the bottom.</li> <li>Portrait - 15mm to the top, left, right, and the bottom.</li> </ul>	M M
	Delivery Address Location <sup>99</sup> (See Figure 52)	<ul style="list-style-type: none"> <li>The Delivery Address must be positioned below and to the right of the Return Address.</li> <li>The Delivery Address must be positioned below and to the left of the Indicia.</li> <li>The Delivery Address block and the Mailmark code must not be printed over or beneath the long flap/seal.</li> </ul>	M M M
		<ul style="list-style-type: none"> <li>The Delivery Address block may be printed on the Polymer or may show through a 'Window' in the Polymer on an insert.</li> </ul>	M
		<ul style="list-style-type: none"> <li>The Delivery Address block and the Mailmark code must not be printed over or beneath the longitudinal seal.</li> <li>Where there is lateral movement of the insert within a Polymer Large Letter and the address is printed on the film, the Delivery Address block must not encroach into a border of 15mm from any edge. In addition, the amount of lateral movement is also required around the perimeter of the envelope where specific clear zones are not defined. i.e. Along the Bottom, Left, and Right edges. e.g. Where the Lateral Movement is 10mm, the required border is 15mm + 10mm = 25mm.</li> </ul>	M M
	Return Address	Fonts	Italic, bold, pseudo script, serifs, computer zero (Ø) and underlining must not be used.
Print Quality		The return address block MUST be printed using a dark colour (preferably black) on a light background.	M
Location		<p>The return address location is determined by the dimensions of the Large Letter :-</p> <p><u>Large Letters up to 162mm x 229mm</u></p> <p>The return address must be located on the back of the Large Letter and centred within the top 40mm (see Figure 54)</p> <p><u>Large Letters over 162mm x 229mm</u></p> <p>The return address must within the top 40mm of the mailpiece and may be located :-</p> <ul style="list-style-type: none"> <li>On the back of the Large Letter and centred. This is the preferred location as it avoids any confusion with the Delivery Address block (see Figure 54), or</li> <li>On the front of the Large Letter from the top left corner to the left end of the indicia area, with no element closer than 75mm from the right edge and no closer than 12mm to the Delivery Address. (see Figure 55 - Figure 56).</li> </ul>	M M

<sup>99</sup> The Large Letter Paper Wrap requirements enable the Indicia, Delivery Address and Return Address to be printed within a 50mm high band. Using a small indicia design will maximise the available space for the address.

### 3.4 Mailmark Large Letters – Mailmark Code

Mailmark requirements are the same as those for Letters except for the location as detailed below.

Category	Specification Requirement	M/R
<b>Location – 2D &amp; 4-State Codes</b>	The Mailmark barcode must not be printed in the border area (see Figure 57 & Figure 58) :	
	<ul style="list-style-type: none"> <li>• Landscape - 15mm to the top, left, right, and the bottom where the Mailmark code is printed a paper, paper wrap, polymer envelope or where it is printed on an insert (carrier sheet) in a poly wrapped Large Letter.</li> </ul>	M
	<ul style="list-style-type: none"> <li>• Portrait - 15mm to the top, left, right, and the bottom where the Mailmark code is printed a paper, paper wrap, polymer envelope or where it is printed on an insert (carrier sheet) in a poly wrapped Large Letter.</li> </ul>	M
	<ul style="list-style-type: none"> <li>• Where there is Lateral Movement of the Insert within a Polymer Wrap Large Letter and the address is printed on the film, if the outer is larger than the insert, the border clear zone increases because the excess film may fold under the insert during processing. The Mailmark Code must not encroach into a border of 15mm, plus the amount of excess poly (this is lateral insert movement) which can be a maximum of 30mm. e.g. 20mm excess poly plus the 15mm border clear zone requirement means that the barcode would be printed 35mm from the edge of the wrap</li> </ul>	M
	<ul style="list-style-type: none"> <li>• The Mailmark Code may be printed within the Indicia Area provided the Indicia and Mailmark clear zones are maintained.</li> </ul>	M
<ul style="list-style-type: none"> <li>• The code must not be printed over the edge of the envelope flap or under the longitudinal seal.</li> </ul>	M	

### 3.5 Mailmark Large Letters - Figures

Figure 46 - Large Letter Lateral Movement (Not to Scale)

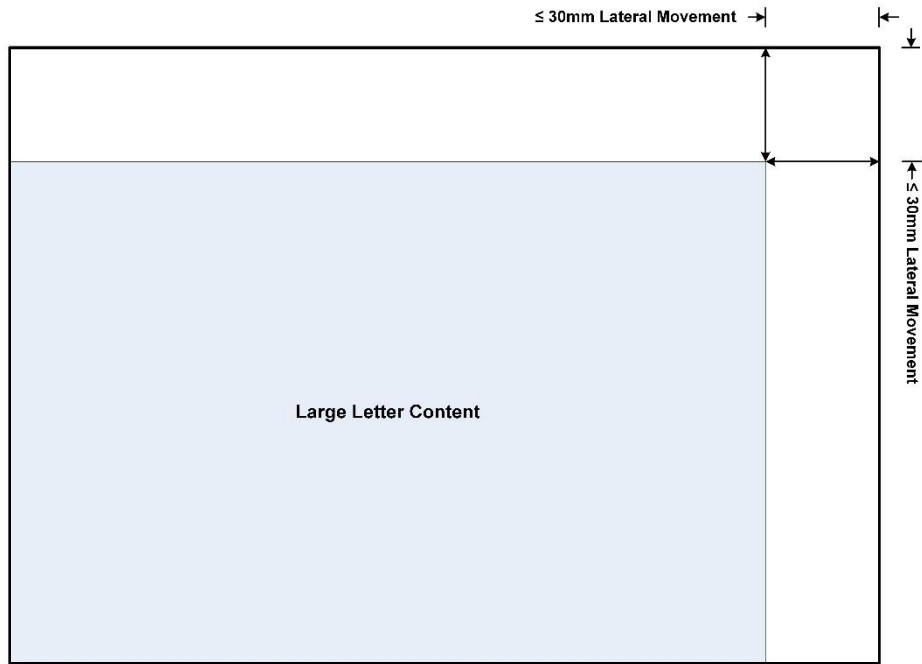

Figure 47 - Large Letter Flexibility (Not to Scale)

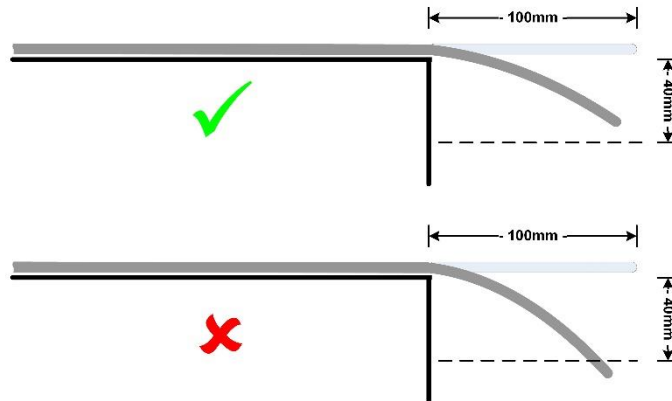

Figure 48 - Large Letter Sealing - Paper (Not to Scale)

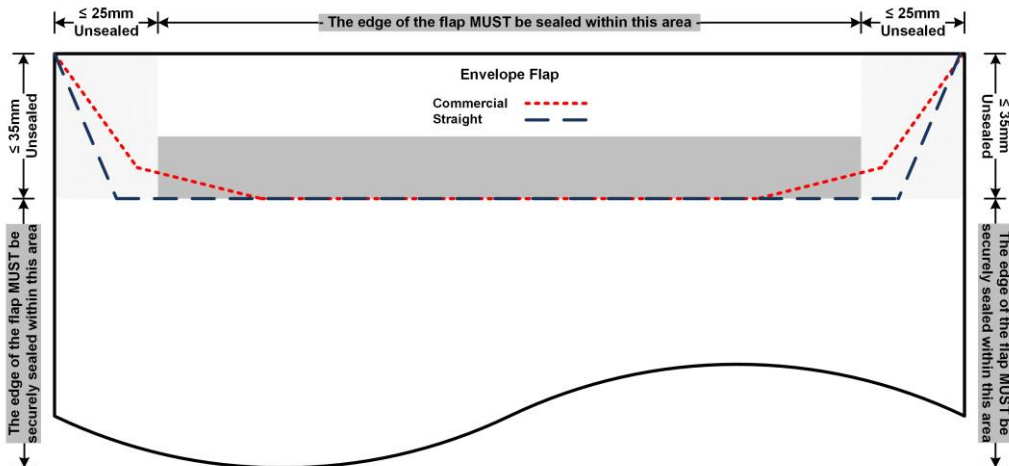

Figure 49 – Large Letter Sealing – Poly Envelope (Not to Scale)

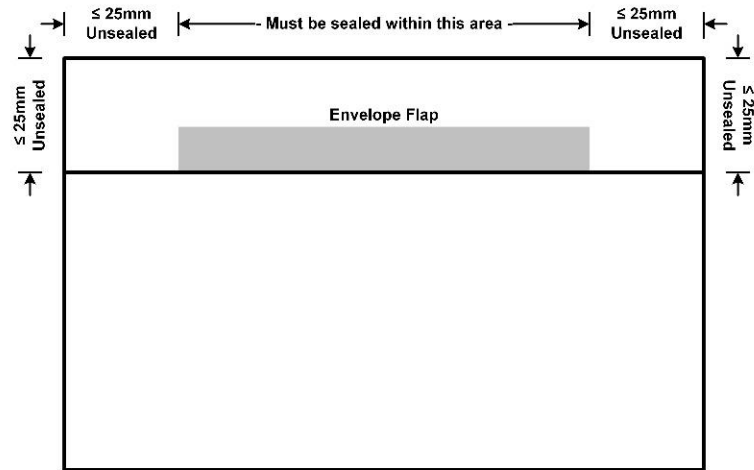

Figure 50 – Large Letter Separation – (Not to Scale)

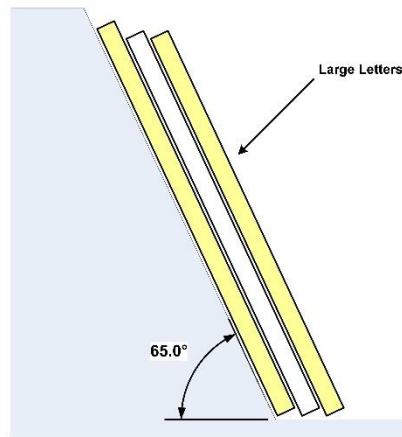

Figure 51 – Large Letter Gatefold – (Not to Scale)

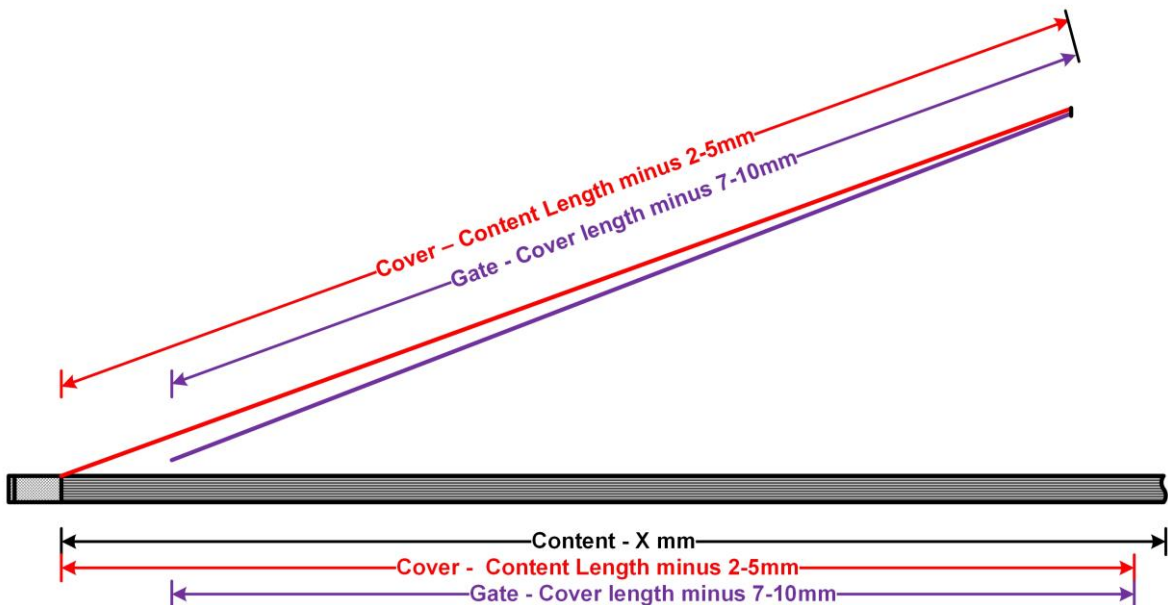

Figure 52 – Large Letter Paper Wrap – Printing (Not to scale)

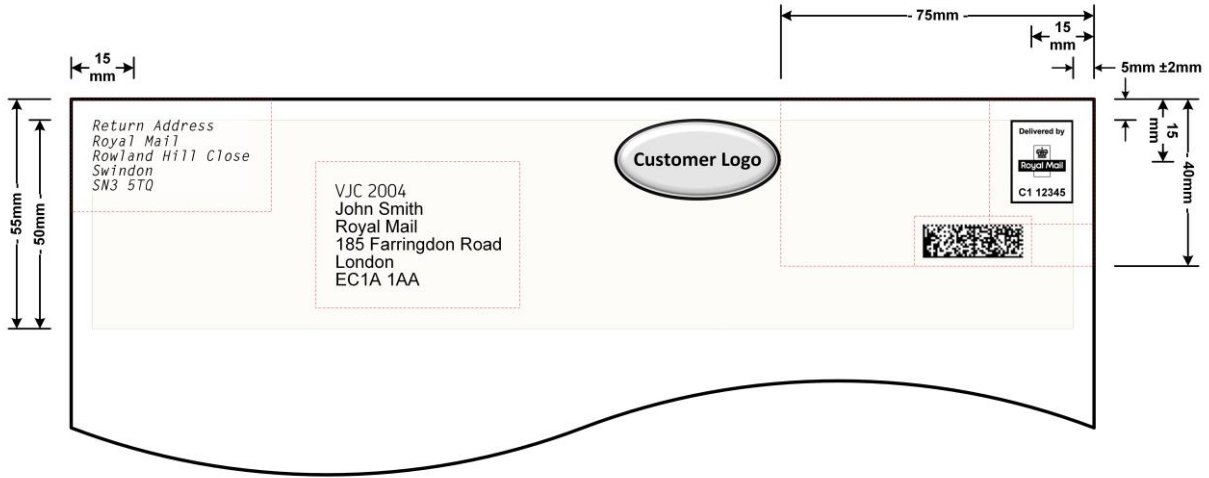

Figure 53 – Large Letter Longitudinal Seal – Poly Wrap (Not to Scale)

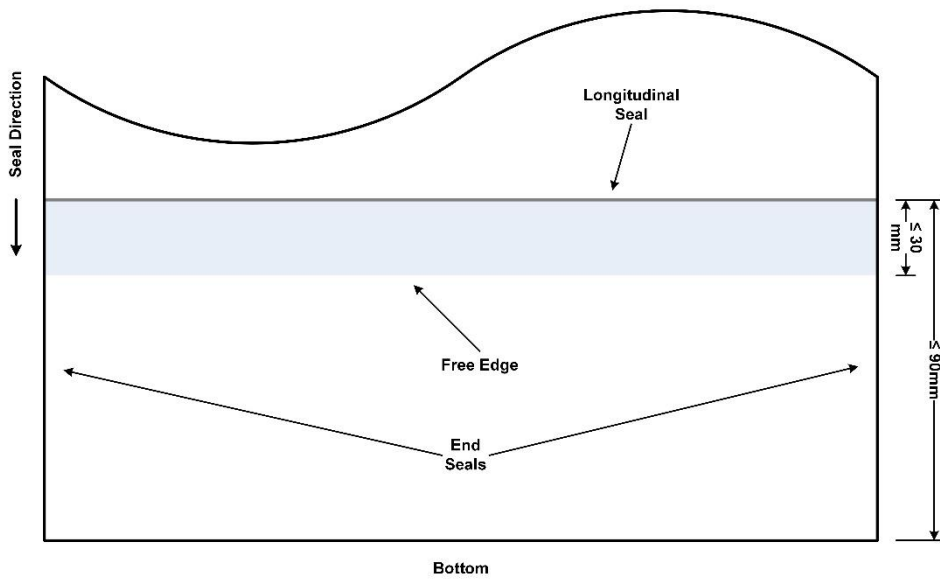

Figure 54 – Large Letter Return Address Preferred – Back (Not to Scale)

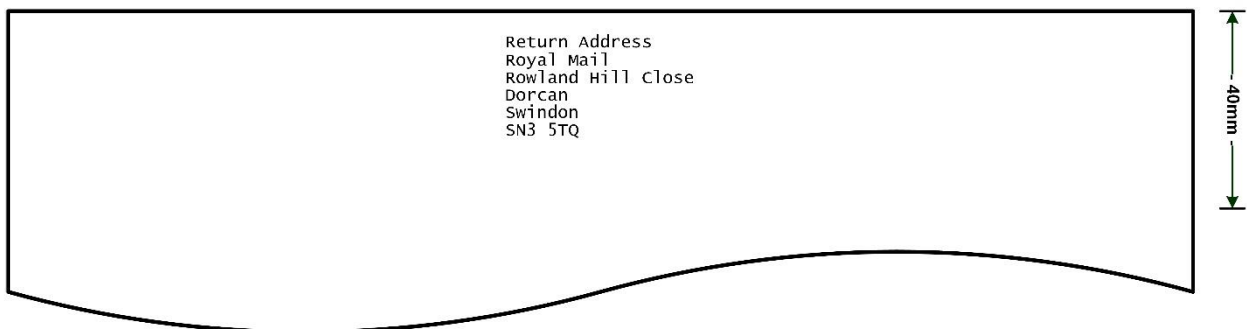

Figure 55 – Large Letter Return Address – Front Landscape Example A (Not to Scale)



Figure 56 – Large Letter Return Address – Front Landscape Example B (Not to Scale)

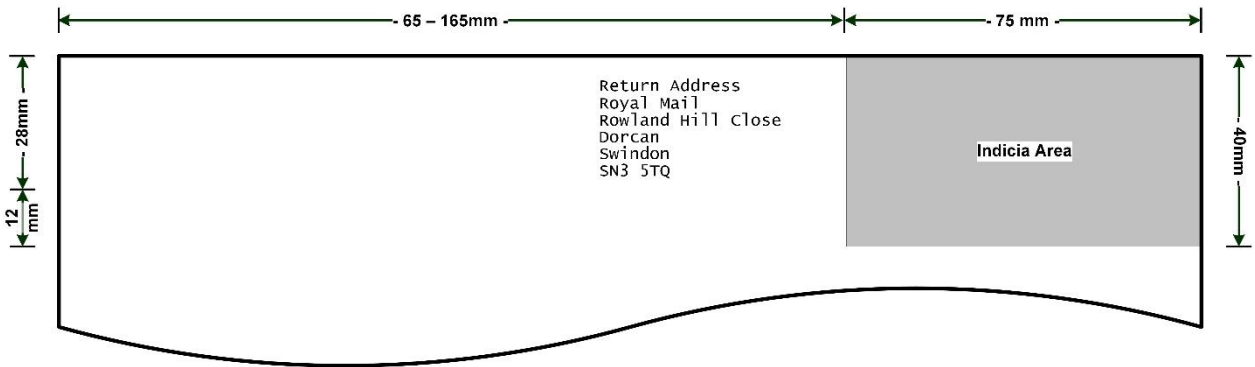

Figure 57 – Large Letter Clear Zones – Landscape (Not to Scale)

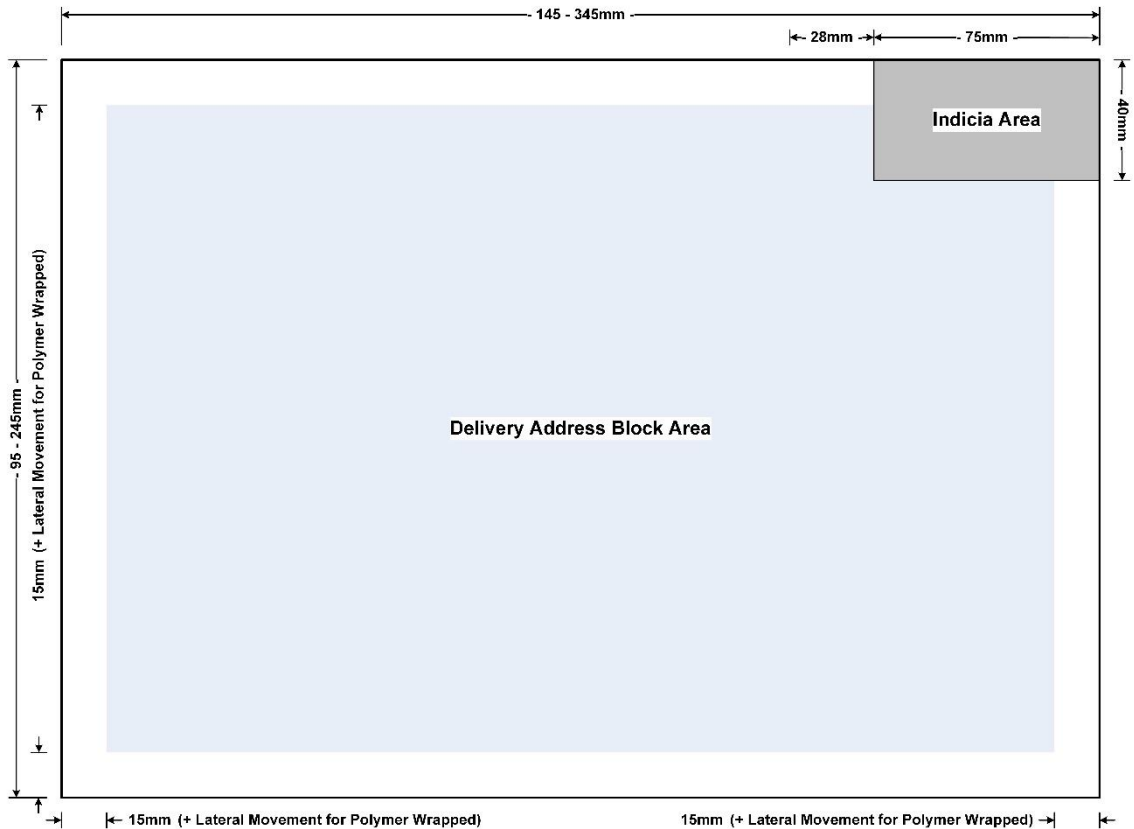

Figure 58 – Large Letter Clear Zones – Portrait (Not to Scale)

